

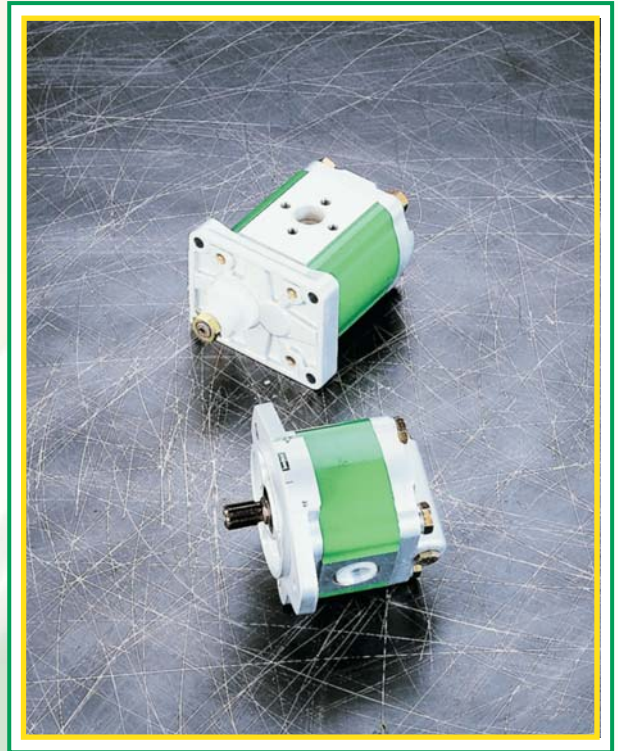

 **LEHENGOVAK, S. A.**

## PRODUCT CARD



# GEAR PUMPS AND MOTORS "B" SERIES GROUP 2

E0.15.0703.02.01



 **LEHENGOVAK, S. A.**

**Page 1 - GENERAL INDEX**

Page 2 - Features - Quick guide

Page 3 - Features - General - Working conditions - Fire resistant fluid

Page 4 - Features - Drive shaft - Pump rotation direction - Hydraulic pipe lines

Page 5 - Features - Filtration index recommended - Tightening torque - Common formulas

Page 6 - Features - Identification label

Page 7 - Features - Changing rotation instructions

Page 8 - 2P/MB GROUP 2

Page 9 - Combination with types of flanges and drives shafts available

Page 10 - Assembling dimensions and values of pressure and speed

Page 11 - Flanged ports - Threaded ports

Page 12 - Drive shafts

Page 13 - Drive shafts - Mounting flanges

Page 14 - Mounting flanges

Page 15 - Outrigger bearing

Page 16 - Mounting flanges with support bearing

Page 17 - Rear covers

Page 18 - Rear cover for multiple pump 2PB/1 PB - Rear covers with main relief valve

Page 19 - Rear cover with flow control valve

Page 20 - Rear cover with priority flow divider valve

Page 21 - Rear cover with load-sensing priority flow divider valve

Page 22 - Rear cover with electric unloading valve and main relief + electric unloading valve

Page 23 - Multiple gear pumps - Assembling dimensions

Page 24 - Multiple pump with separated stages - 2PB combination with 1PB

Page 25 - 26 - 27 - Pump performance curves

Page 28 - 29 - 30 - Motor performance curves

Page 30 - Port connectors

Page 31 - How to order - Single pumps

Page 32 - How to order - Multiple pumps

**Page 33 - WARRANTY**

**E0.15.0703.02.01**

The data in this catalogue refers to the standard product.

The policy of Salami S.p.A. consists of a continuous improvement of its products. It reserves the right to change the specifications of the different products whenever necessary and without giving prior information.

If any doubts, please get in touch with our sales department.



### QUICK GUIDE TO SELECT THE RIGHT PUMP SIZE

#### Definition of pressures

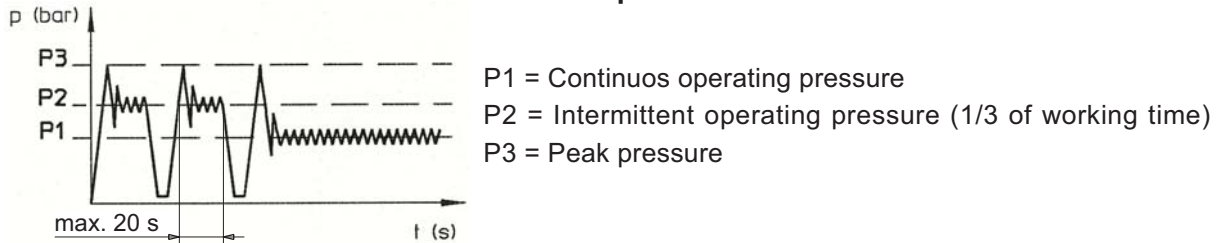

The diagram shown here below is used as a first dimensioning aid for the choice of pump group. It is based on the value of displacements (horizontal coordinates) and intermittent pressure  $P2$  (vertical coordinates)

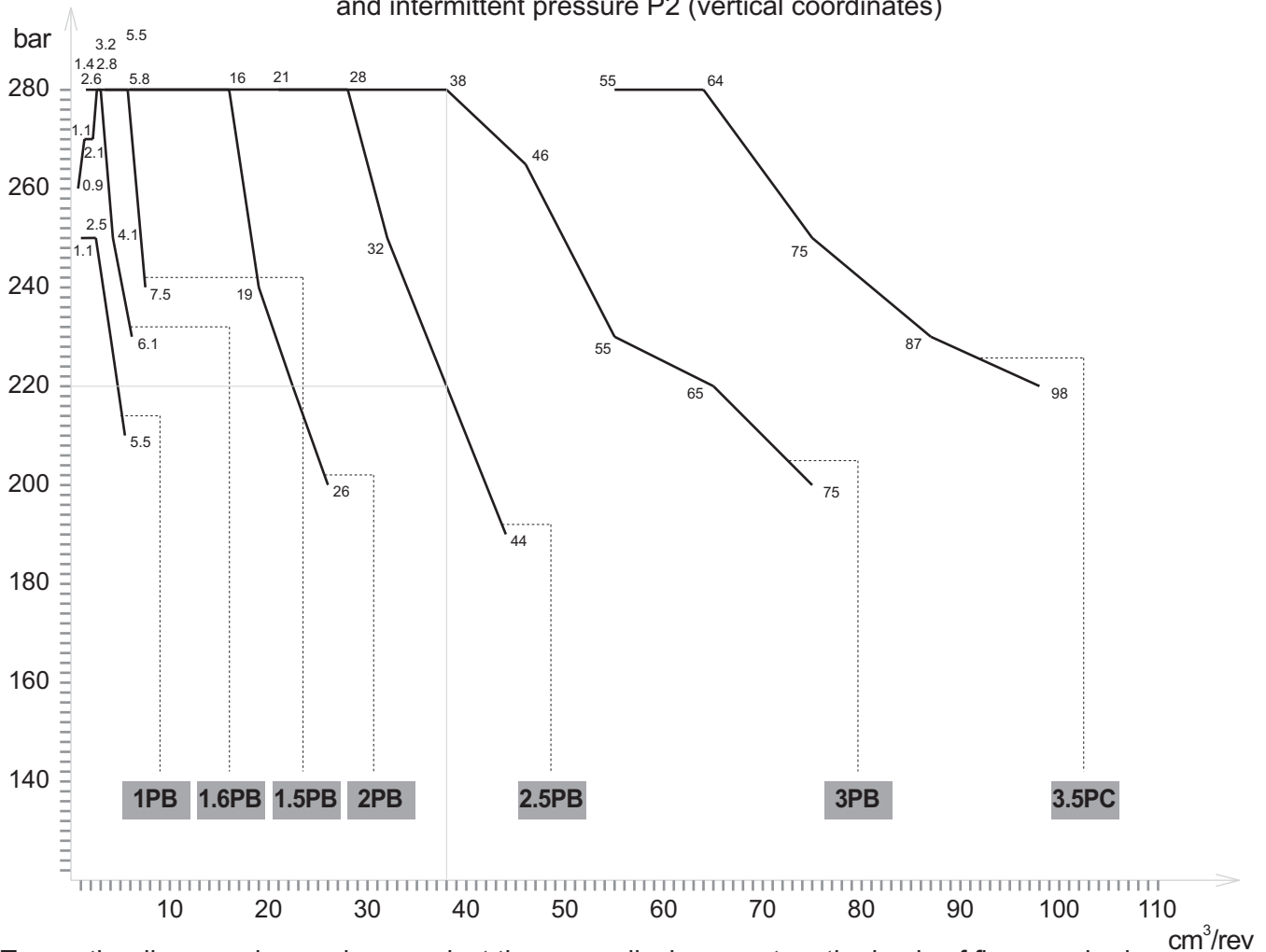

To use the diagram shown above, select the pump displacement on the basis of flow required. Then draw a vertical line to intersect the line representing the pump series. Now you can select the group on the basis of required application pressure.

**Example: 38  $\text{cm}^3/\text{rev}$  — 2.5PB 38 220 bar (3140 psi)**  
**If required application pressure is more than 220 bar, use a 3 PB**

**GENERAL**

SALAMI gear pumps and motors are available in seven series giving options of displacements from 1.1 cm<sup>3</sup>/rev to 98 cm<sup>3</sup>/rev(from 0.06 cu.in./rev to 6.03 cu.in./rev).

All pumps are available as multiple units either of the same or different series.

With all sizes of pumps and motors there are options of shafts, flanges and ports as for European, German and American standards.

SALAMI gear pumps and motors offer:

- High volumetric efficiency by innovative design and accurate control of machining tolerances.
- Axial compensation achieved by the use of floating bushes that allow high volumetric efficiency throughout the working pressure range.
- DU bearings ensure high pressure capability.
- 12 teeth integral gear and shaft.
- Extruded alluminum body.
- Die cast alluminum cover and flange - cast iron rear.
- Double shafts seals in all pump series except Group 1.
- Nitrile seals as standard and viton seals in high temperature applications.

All pumps and motors are hydraulic tested after assembly to ensure the high standard performance required by SALAMI'S engineering.

**WORKING CONDITIONS**

**THE VALUES OF PRESSURE ARE ABSOLUTE**

- Pump inlet pressure ..... 0,7 to 2,5 bar  
10 to 36 *psi*
- Return pipe line continuous pressure for motors ..... MAX 2,5 bar - 36 *psi*
- Return pipe line intermit. pressure for motors ..... MAX 6 bar for 15 sec - 85 *psi*
- Return pipe line peak pressure for motors ..... MAX 15 bar - 215 *psi*
- Minimum operating fluid viscosity ..... 12 mm<sup>2</sup> / sec
- Max starting viscosity ..... 800 mm<sup>2</sup> / sec
- Suggested fluid viscosity range ..... 17 - 65 mm<sup>2</sup> / sec
- Fluid operating temperature range ..... -15 to +85 °C
- Hydraulic fluid ..... mineral oil

Important:

in case of assembling of pumps without shaft seals (eg. B2 - B3...), you have to keep the value of min. suction pressure ( 0.7 bar (abs)) in the vane between pump and coupling too.

Lower pressure can lead to suction of oil through the front flange (seat of the shaft without seal); this can damage seriously the pump.

**FIRE RESISTENT FLUID**

Type	Description	Max pressure	Max speed (rpm)	Temperature
HFB	oil emulsion with 40% water	130 bar/1880 <i>psi</i>	2500	3°C +65°C
HFC	Water glycol	180 bar/2600 <i>psi</i>	1500	-20°C +65°C
HFD	Phosphate esters		1750	-10°C +80°C



### DRIVE SHAFT

Radial and axial loads on the shafts must be avoided since they reduce the life of the unit. Pumps driven by power take - off on engines must always be connected by placing an "Oldham" coupling or coupling having convex toothed hub. This is to ensure that inevitable misalignment during assembly is reduced to minimum.

### PUMP ROTATION DIRECTION VIEWED AT THE DRIVE SHAFT

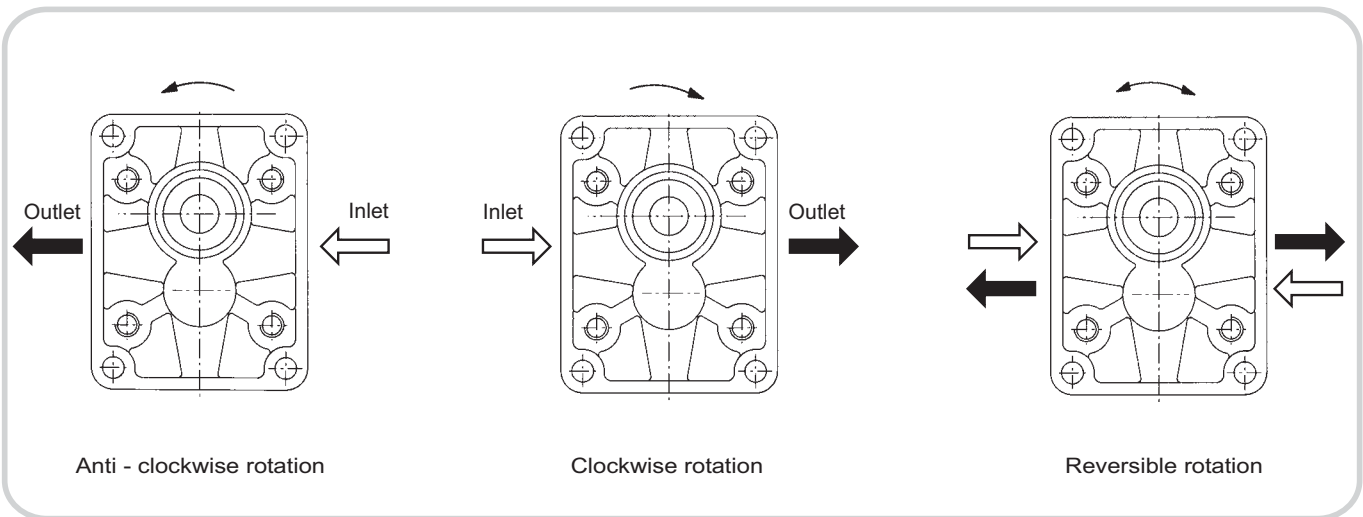

### HYDRAULIC PIPE LINE

To ensure favorable suction conditions it is important to keep pressure drop in suction pipe line to a minimum value (see WORKING CONDITIONS).

To calculate hydraulic pipe line size, the designer can use; as an approximate guide, the following fluid speed figures:

From 1 to 2 m/sec on suction pipe line  
From 6 to 10 m/sec on pressure pipe line

From 3.28 to 6.36 ft/sec on suction pipe line  
From 19.7 to 32.8 ft/sec on pressure pipe line

The lowest fluid speed values in pipe lines is recommended when the operating temperature range is high and/or for continuous duty.

The highest value is recommended when the temperature difference is low and/or for intermittent duty.

**When tandem pumps are supplied by 2 different reservoirs with 2 different fluids it is necessary to specify "AS" version.**

In case of reversible motor allowance must be made to ensure the motor is not drained, through the case drain, when stationary.

**FILTRATION INDEX RECOMMENDED**

Working pressure	> 200 bar / 2900 psi	< 200 bar / 2900 psi
Contamination class NAS 1638	9	10
Contamination class ISO 4406	18/15	19/16
Achieved with filter $\beta_x = 75$	15 $\mu\text{m}$	25 $\mu\text{m}$

**TIGHTENING TORQUE**

**OUR BOLTS AND TIE-RODS HAVE ALWAYS HEATING TREATMENT OF BLACK BURNISHING**

PUMP TYPE		BOLT TYPE		TORQUE Nm	FOR SCREWS ZINC PLATED REDUCE TIGHTENING TORQUE OF 10%
SIZE	SERIE	DIAMETER	CLASS		
1	B SINGLE	M 8 x 1.25	8.8	20.5 - 25.5	
1	B MULTIPLE	M 8 x 1.25	8.8	20.5 - 25.5	
2	B SINGLE	M 10 x 1.5	8.8	47 - 51	
2	B MULTIPLE	M 10 x 1.5	10.9	50 - 55	
2.5	B SINGLE	M 12	8.8	70 - 75	
2.5	B MULTIPLE	M 12	10.9	75 - 80	
3	B	M 10	HEX. BOLT <b>10.9</b> HEX. SOCKET H.C.B. <b>12.9</b>	47 - 51	
3.5	C	M 12	8.8	74 - 85	
3	H	M 14	10.9	BOLT 180 150 - 160 TIE ROD	

**COMMON FORMULAS**

$$C = \text{Input torque} = \frac{q \cdot \Delta p}{62.8 \cdot \eta_m} \text{ (Nm)}$$

$$P = \text{Input power} = \frac{q \cdot n \cdot \Delta p \cdot 10^{-3}}{600 \eta_m} \text{ (kW)}$$

$$Q = \text{Outlet flow} = \frac{q \cdot n \cdot \eta_v}{1000} \text{ (l/min)}$$

**LEGENDA**

$\Delta p$  = Working pressure (bar)

$q$  = Displacement ( $\text{cm}^3/\text{rev}$ )

$n$  = Speed ( $\text{min}^{-1}$ )

$\eta_m$  = Mechanical eff. (0.92)

$\eta_v$  = Volumetric eff. (0.95)

### Description of the product identification label

Based on the firm certification ISO 9001 - UNI EN 29001, section 4.8 (identification and traceability of the product), we have adopted a new identification label starting from the 1<sup>st</sup> march 1995. Pls, see following example:

A			
B			
C		D	
E	salami	F	G

- A = Product short description (VD8A/FDD/U4G).**
- B = Customer part number.**
- C = Salami part number (6235 0025 0).**
- D = Production batch (for Salami management)**
- E = Rotation sense (only for pumps).**
- F = Manufacturing date (see data sheet here below)**
- G = Progressive number of assembling.**

Only for pumps 2PB and 2PZ (except triple 2PB) the identification product is marked on the top of the pump body as shown here below:

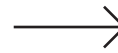

**SALAMI 09/02**  
**MADE IN ITALY 4010998**  
**612271211 nr. 13**  
**2PB 19S B25 B5**

- Product short description. \_\_\_\_\_
- Salami part number and progressive number of assembling. \_\_\_\_\_
- Production code (for Salami management). \_\_\_\_\_
- Month and year of made: maybe in the future you can find this type of production date in the label beside too. \_\_\_\_\_
- Rotation sense. \_\_\_\_\_

	1990	1991	1992	1993	1994	1995	1996	1997	1998	1999	2000	2001	2002	2003	2004	2005
JANUARY	0A	1A	2A	3A	4A	5A	6A	7A	8M	9M	0M	1M	2M	3M	4M	5M
FEBRUARY	0B	1B	2B	3B	4B	5B	6B	7B	8N	9N	0N	1N	2N	3N	4N	5N
MARCH	0C	1C	2C	3C	4C	5C	6C	7C	8P	9P	0P	1P	2P	3P	4P	5P
APRIL	0D	1D	2D	3D	4D	5D	6D	7D	8Q	9Q	0Q	1Q	2Q	3Q	4Q	5Q
MAY	0E	1E	2E	3E	4E	5E	6E	7E	8R	9R	0R	1R	2R	3R	4R	5R
JUNE	0F	1F	2F	3F	4F	5F	6F	7F	8S	9S	0S	1S	2S	3S	4S	5S
JULY	0G	1G	2G	3G	4G	5G	6G	7G	8T	9T	0T	1T	2T	3T	4T	5T
AUGUST	0H	1H	2H	3H	4H	5H	6H	7H	8U	9U	0U	1U	2U	3U	4U	5U
SEPTEMBER	0I	1I	2I	3I	4I	5I	6I	7I	8V	9V	0V	1V	2V	3V	4V	5V
OCTOBER	0J	1J	2J	3J	4J	5J	6J	7J	8Z	9Z	0Z	1Z	2Z	3Z	4Z	5Z
NOVEMBER	0K	1K	2K	3K	4K	5K	6K	7K	8X	9X	0X	1X	2X	3X	4X	5X
DECEMBER	0L	1L	2L	3L	4L	5L	6L	7L	8Y	9Y	0Y	1Y	2Y	3Y	4Y	5Y





**Rotation changing instructions for pumps GROUP 2 - 2.5 - 3 - 3.5**

Before starting, be sure that the pump is cleaned externally as well as the working area to avoid that particles dangerous for pump working can find their way into the pump.

Pump represented is aclockwise rotation pump.

To obtain an anti\_clockwise rotation read carefully the following instructions.

**Picture "A"**

- 1 - Loosen and fully unscrew the clamp bolts.
- 2 - Lay the pump on the working area in order to have the mounting flange turned upside.
- 3 - Coat the shaft extension with grease to avoid damaging the shaft seal.
- 4 - Remove the flange and lay it on the working area; verify that the seal is correctly located in the body seat.

**Picture "B"**

- 1 - Mark the position of the bushing and eventually the thrust plate, relative to the body.
- 2 - Remove the bushing, thrust plate and the driving gear taking care to avoid driven gear axial shifts.

**Picture "C"**

- 1 - Draw out the driven gear from its housing, taking care to avoid rear cover axial shifts.
- 2 - Re-locate the driven gear in the position previously occupied by the driving gear.

**Picture "D"**

- 1 - Re-locate the driving gear in the position previously occupied by the driven gear.

**Picture "E"**

- 1 - Replace the bushing and thrust plate taking care that:
  - marks are located as on the picture
  - surface containing the seal is visible
  - seal and its protection are correctly located

**Picture "F"**

- 1 - Clean body and mounting flange refaced surfaces.
- 2 - Verify that the two plugs are located in the body.
- 3 - Refit the mounting flange, turned 180° from its original position.
- 4 - Replace the clamp bolts and tighten crosswise evenly to a torque of 40 - 45 Nm for 2PB, 2.5PB, 45 - 50 Nm for 3PB, 3.5PB.
- 5 - Check that the shaft rotates freely.
- 6 - Mark on the flange the new direction of rotation.

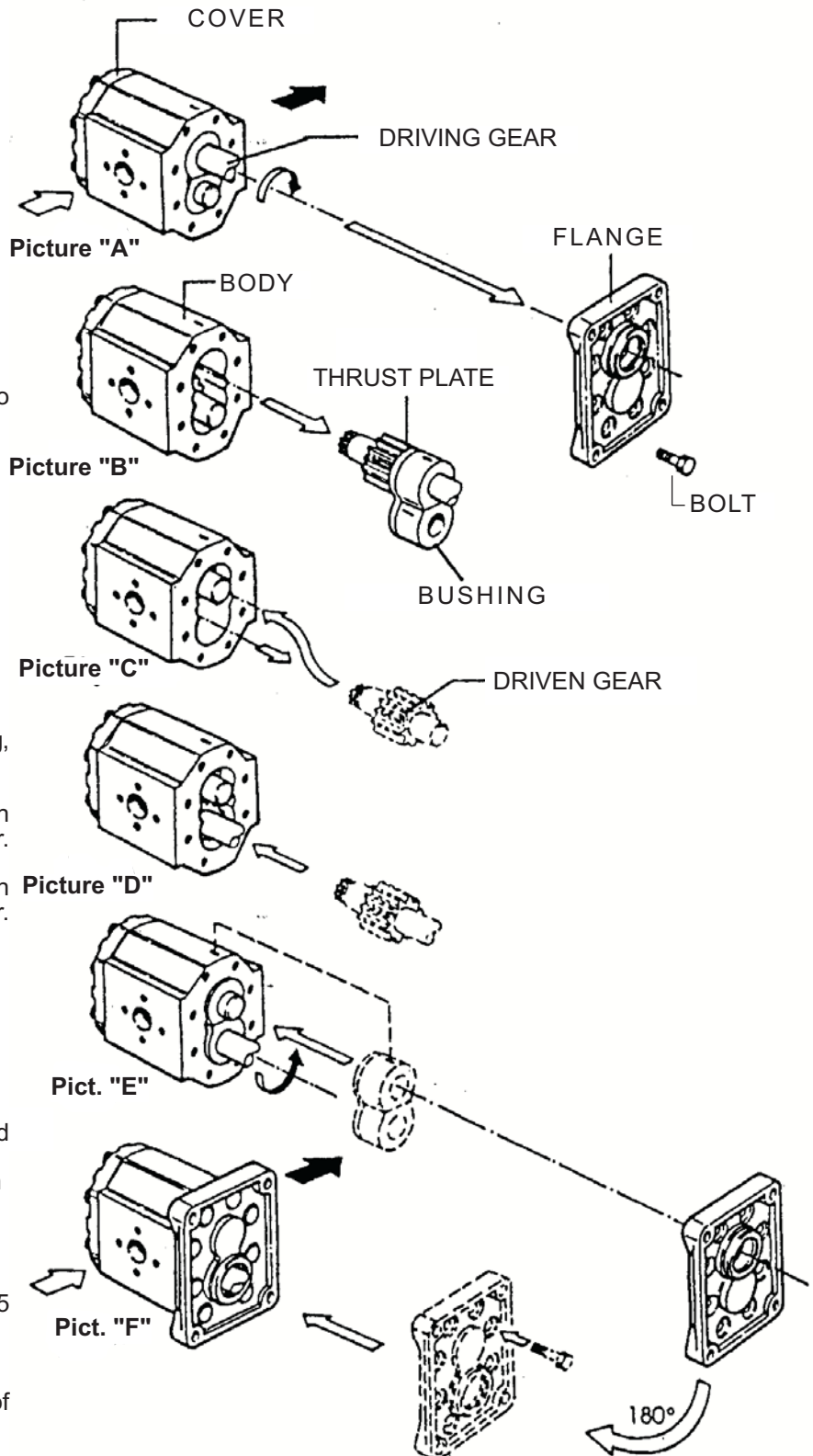

**IMPORTANT: TO AVOID A PERFORMANCE LOSS DO NOT CHANGE MOTOR ROTATION**



# 2P/MB Group 2



## GEAR PUMP IN DETAIL

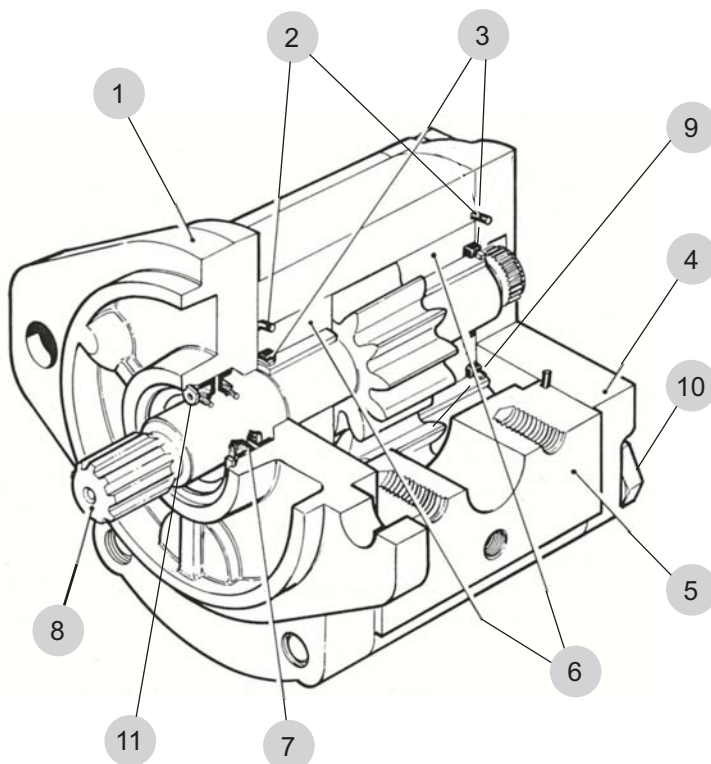





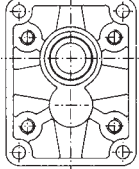
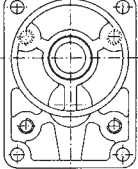
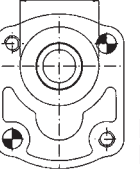
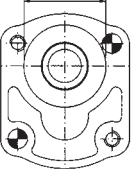
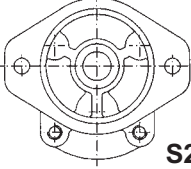

- 1 - Flange
- 2 - Body seal
- 3 - Bushing seals and anti-extrusion
- 4 - Cover
- 5 - Body
- 6 - Bushings
- 7 - Rotary shaft seal
- 8 - Drive gear
- 9 - Driven gear
- 10 - Screws
- 11 - Stop ring

This drawing can be considered an example of standard components of group 2 pump.

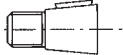

**COMBINATION WITH TYPES OF FLANGES AND DRIVES SHAFTS AVAILABLE**

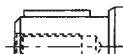
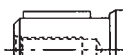
<b>2PB</b>	 <b>P1</b>	 <b>B1</b>	 <b>B4 B5</b>	 <b>B2 B3</b>	 <b>S2</b>
 <b>28</b>	28 P1				
 <b>25</b>		25 B1	25 B4-B5		
 <b>61-62</b>	62 P1	62 B1	62 B4-B5	61 B2-61B3	
 <b>03</b>				03 B2-03 B3	
 <b>52</b>					52 S2
 <b>54</b>					54 S2
 <b>85</b>					85 S2
 <b>82</b>	82 P1				82 S2

Note: other versions available, see shafts and flanges information.

# 2P/MB / Group 2

# GEAR PUMPS AND MOTORS "B" SERIES

Displacements up to 1.58 cu.in./rev  
Pressure up to 4300 psi

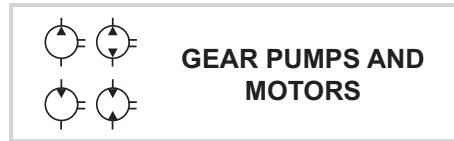

Displacements up to 25.8 cm<sup>3</sup>/rev  
Pressure up to 300 bar

## ASSEMBLING DIMENSIONS AND VALUES OF PRESSURE AND SPEED

Type		3.2*	3.9*	4.5	6.2	8.3	11.3	13.8	16	19	22.5	26
Displacement	cm <sup>3</sup> /rev cu.in./rev	3.2 0.19	3.9 0.24	4.6 0.27	6.5 0.40	8.2 0.50	11.5 0.68	13.8 0.84	16.6 1.01	19.4 1.15	22.9 1.37	25.8 1.58
Dimension A	mm in	47.1 1.83			52.8 2.05		63.5 2.50		74 2.91	80.4 3.13	85.8 3.38	91.6 3.61
Dimension C	mm in	23.55 0.91				31.75 1.23		37 1.44	40.2 1.56	42.9 1.67	45.8 1.78	
Working pressure	p1 bar psi	250 3600						220 3140		200 2900	180 2600	
Intermittent pressure	p2 bar psi	280 4000						240 3450		220 3140	200 2900	
Peak pressure	p3 bar psi	300 4300						260 3750		240 3450	220 3140	
Max speed at	p2 rpm	4000				3500			3000		2750	2500
Min speed at	p1 rpm	600				500			400		400	300
Weight	rpm lbs	2.1 4.6				2.25 5.0	2.5 5.5	2.75 6	2.95 6.5	3.1 6.8	3.25 7.2	

\* Available only as rear pump

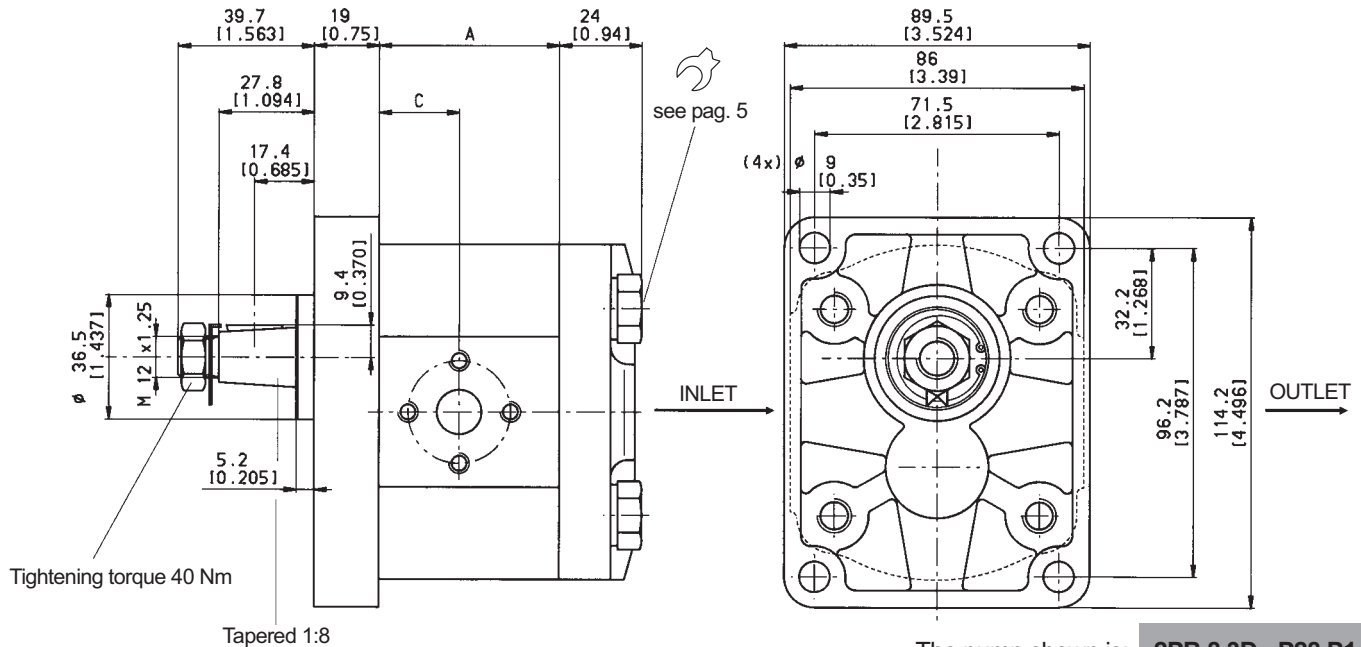

The pump shown is: **2PB 8.3D - P28 P1**

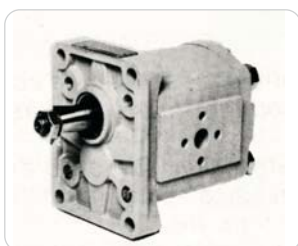

**FLANGED PORTS**

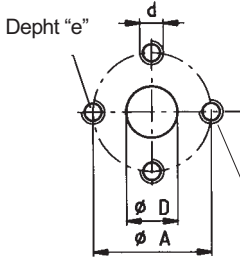

**code P**

Type	INLET				OUTLET			
	ØD	ØA	d	e	ØD	ØA	d	e
From 4.5 to 8.3	13 (0.51")	30 (1.19")	M6	13 (0.51")	13 (0.51")	30 (1.19")	M6	13 (0.51")
From 11.3 to 22.5	20 (0.78")	40 (1.56")	M8					
26	22 (0.87")							

Tightening torques : M6: 10 Nm  
M8: 22 Nm

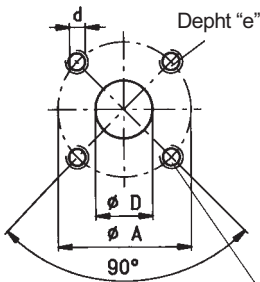

**code B**

Type	INLET				OUTLET			
	ØD	ØA	d	e	ØD	ØA	d	e
From 4.5 to 22.5	20 (0.78")	40 (1.56")	M6	13 (0.51")	15 (0.59")	35 (1.38")	M6	13 (0.51")
26	22 (0.87")							

Note: for unidirectional motor inlet/outlet ports are reversed

Tightening torques : M6: 10 Nm  
M8: 22 Nm

**THREADED PORTS**

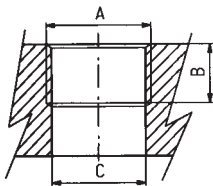

**code G**

British standard pipe parallel (BSPP)

Type	INLET			OUTLET		
	A	B	ØC	A	B	ØC
4.5 - 6.2	G1/2	14 (0.54")	13 (0.51")	G1/2	14 (0.54")	13 (0.51")
From 8.3 to 26	G3/4	16 (0.62")	20 (0.78")			

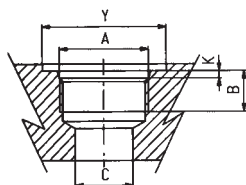

**code R**

SAE threaded (ODT)

Type	INLET					OUTLET				
	A	B	ØC	Y	K	A	B	ØC	Y	K
From 4.5 to 26	1-1/16 UNF (SAE 12)	16 (0.62")	20 (0.78")	41 (1.61")	3.3 (0.12")	7/8 - 14 UNF (SAE 10)	14 (0.54")	13 (0.51")	34 (1.32")	2.5 (0.10")

Note: for unidirectional motor inlet/outlet ports are reversed

## DRIVE SHAFTS

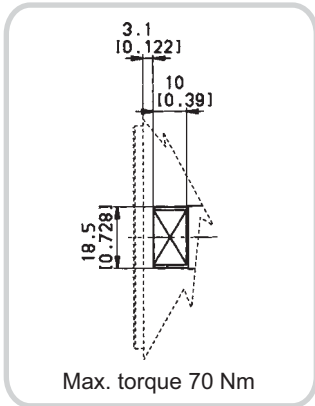

### code 02

Tang drive for diesel engine

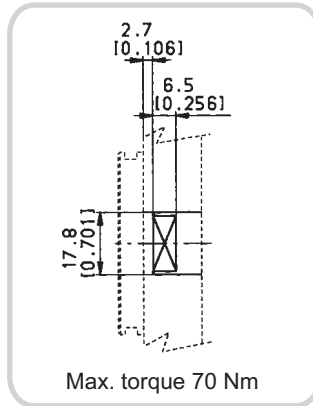

### code 03

Tang drive for electric motors

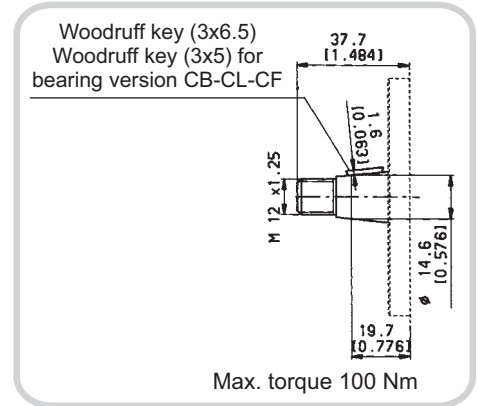

### code 25

Tapered 1:5

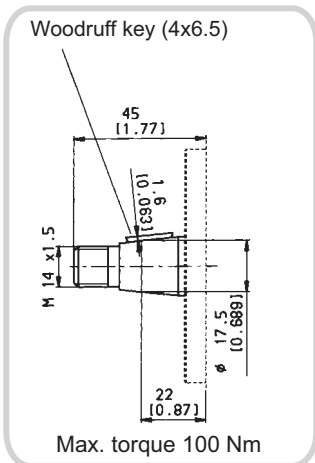

### code 26

Tapered 1:5 (only for CB)

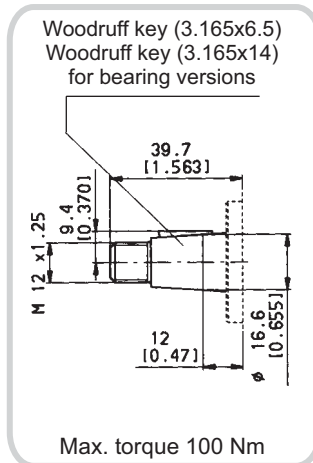

### code 28

Tapered 1:8

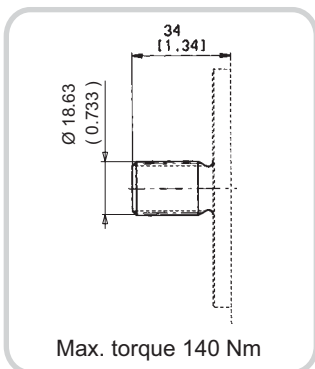

### code 54

SAE A 11T-16/32DP  
Ansi B92 1a 1976

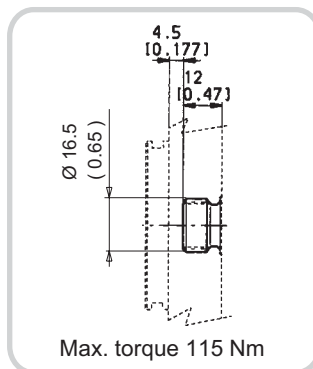

### code 61

DIN 5482 splined

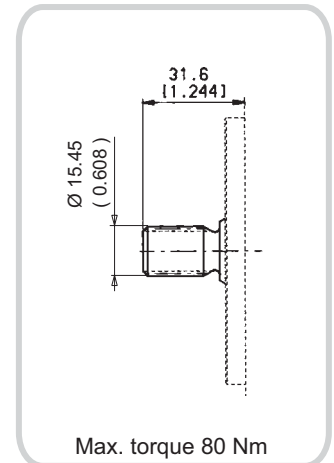

### code 52

SAE A 9T-16/32DP  
Ansi B92 1a 1976

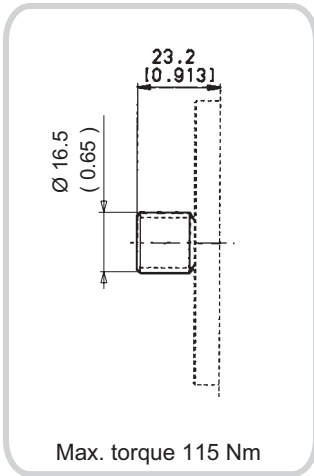

**code 62**

9 teeth DIN 5482  
splined

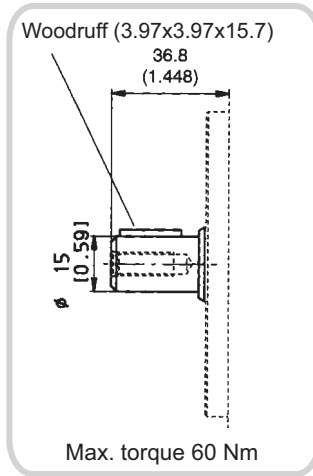

**code 81**

Parallel available  
on request

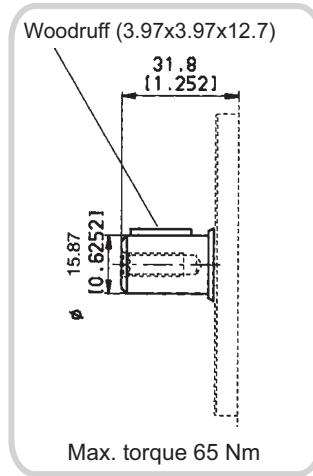

**code 82**

5/8" SAE A parallel

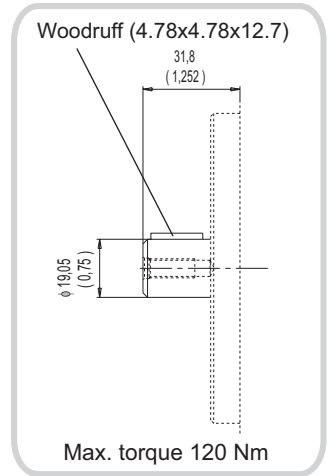

**code 85**

3/4" SAE A parallel

**MOUNTING FLANGES**

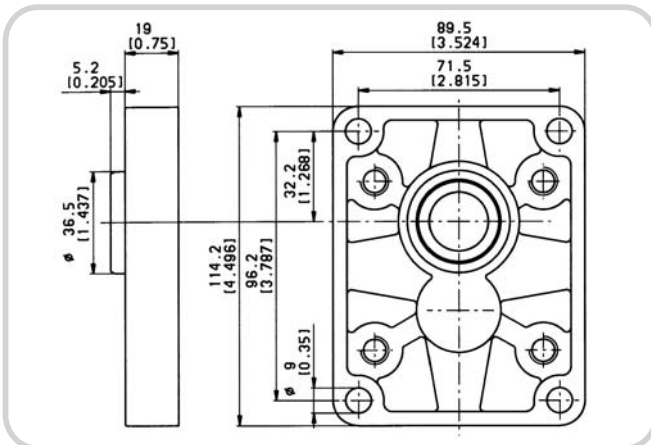

With shaft code 28 - 62 - 81 - 82 - 85

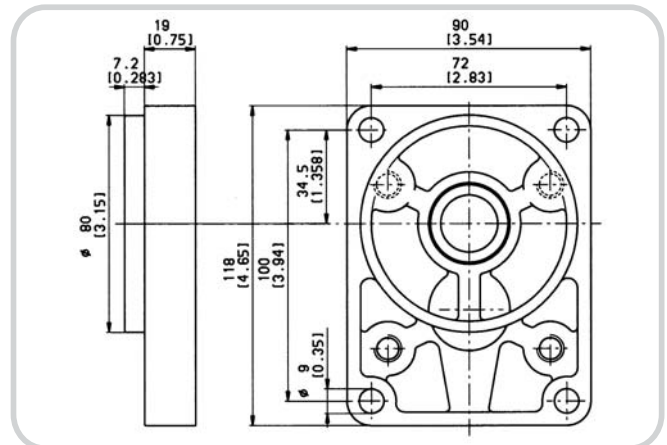

With shaft code 25-62

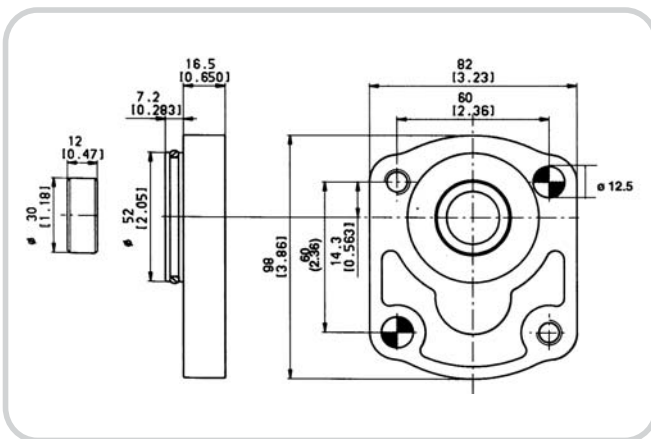

With shaft code 03-61

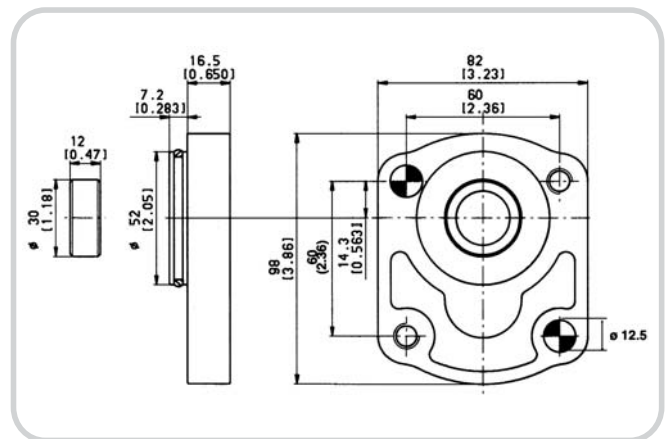

With shaft code 03-61



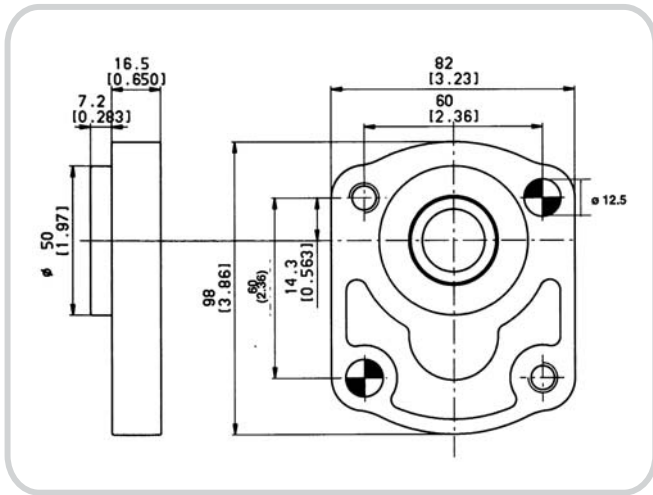

**code B4** With shaft code 25-62

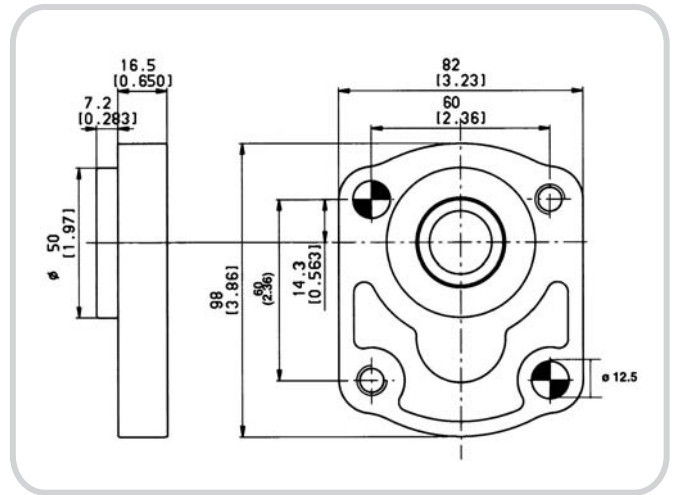

**code B5** With shaft code 25-62

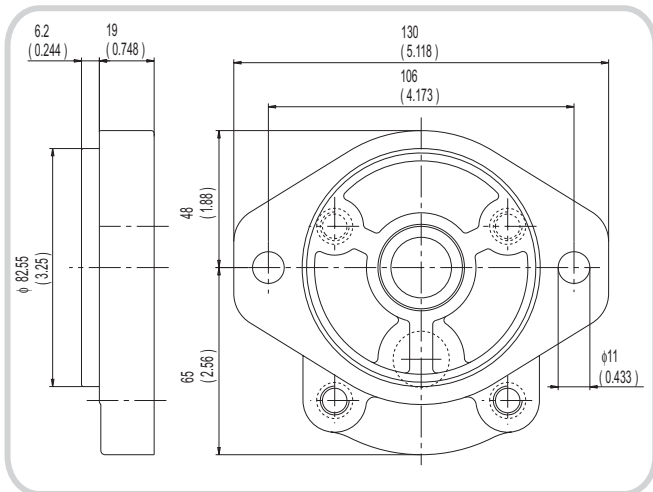

**code S2** With shaft code 52-54-82-85.

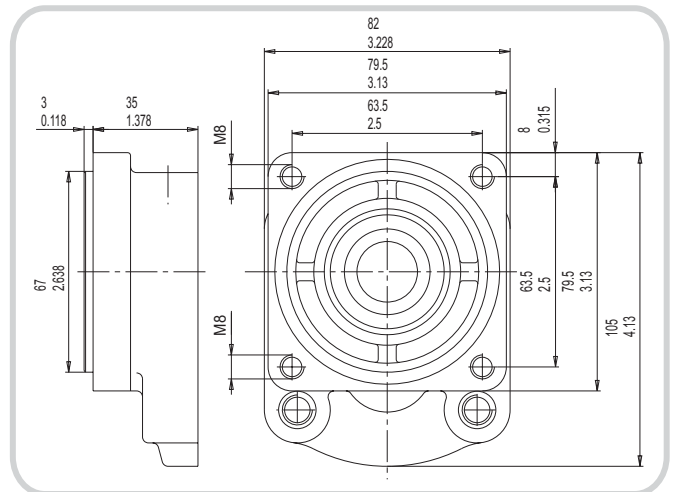

**code K1** With shaft code 02.  
For Perkins engines (series 100)

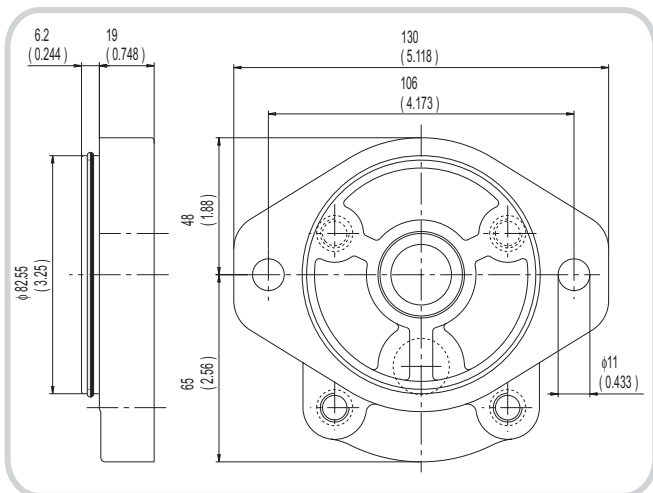

**code S6** With shaft code 52-54-82-85

**OUTRIGGER BEARING**

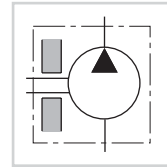
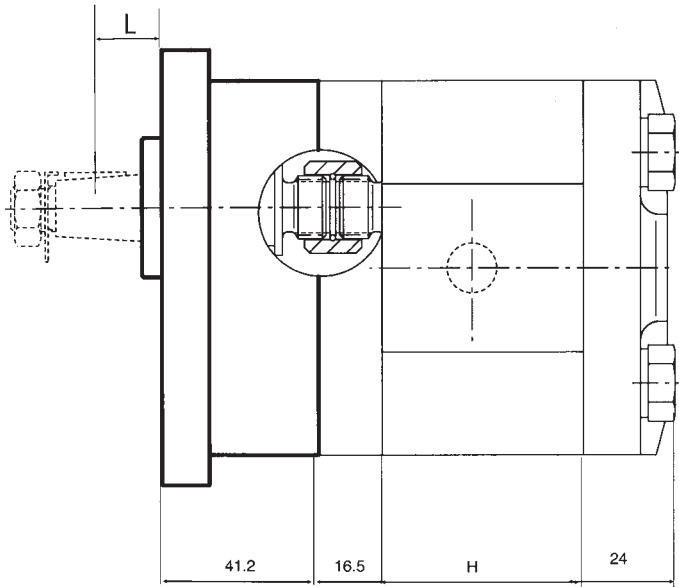

Type	H
4.5 - 6.2	47.1 (1.85")
8.3	52.8 (2.07")
11.3 - 13.8	63.5 (2.50")
16	74 (2.91")
19	80.4 (3.16")
22.5	85.8 (3.37")
26	91.6 (3.60")

Order example pump 2PB with bearing: **2pB 16D - B25 B4 - CF**

**Life of bearing under following condition:  
L=18 mm ( 0.71" ) D (Pulley diameter)=90 mm ( 3.54" )**

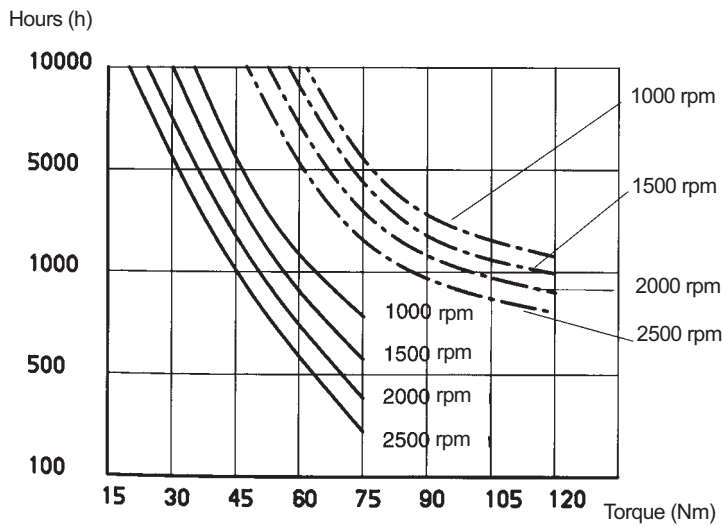

To calculate the absorbed pump or motor torque, please use the following formula:

$$C \text{ (Nm)} = \frac{C_y \Delta p}{62.8 \eta_m}$$

$C_y$  = Displacement ( cm<sup>3</sup>/rev )

$\Delta p$  = Pressure ( bar )

For Code CP-CB-CL-CS

\_\_\_\_\_

-----

For Code CF

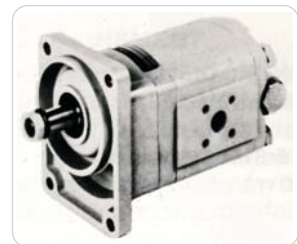
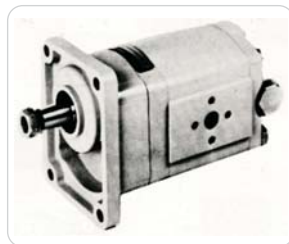

## MOUNTING FLANGES WITH BEARING SUPPORT

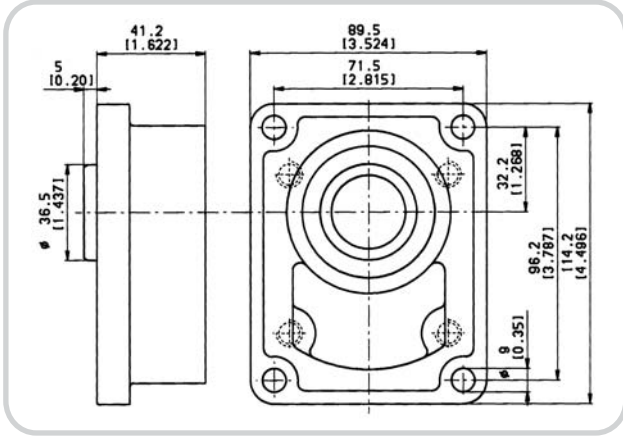

**code CP** With shaft code 28

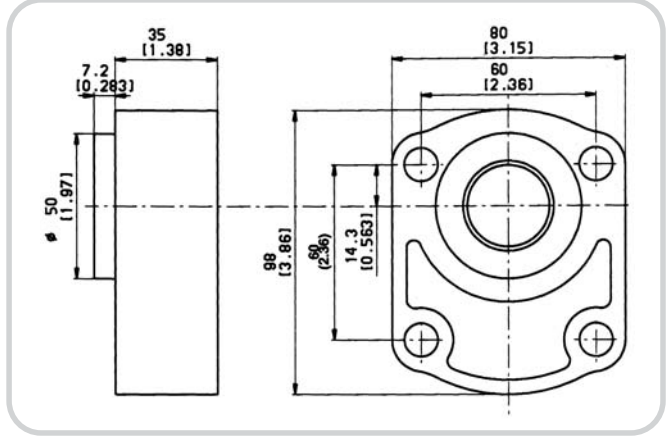

**code CL** With shaft code 25, 26

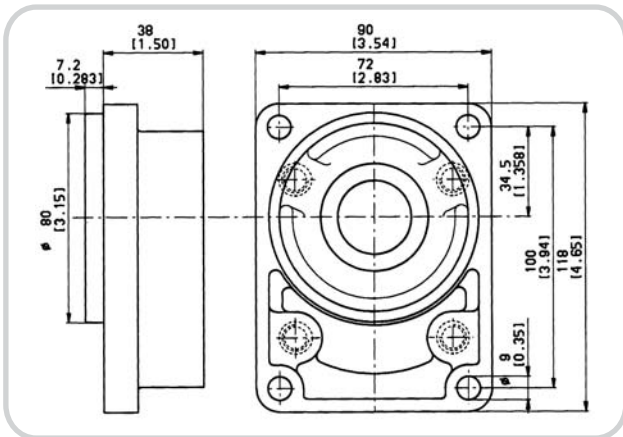

**code CB** With shaft codes 25-26

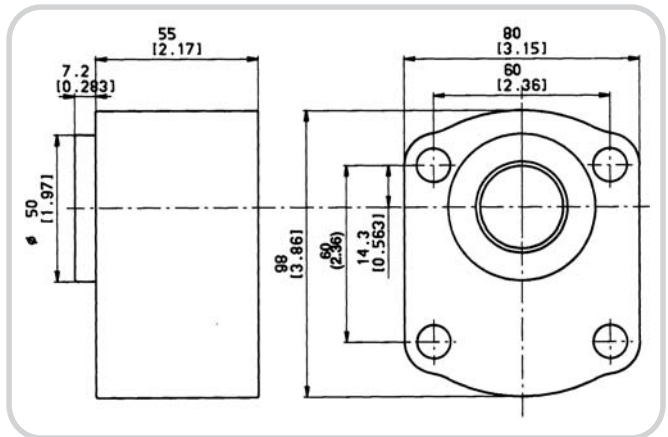

**code CF** With shaft code 25, 26

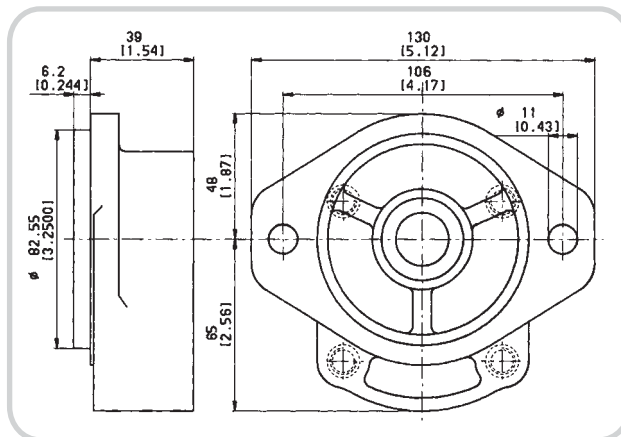

**code CS** SAE A with shaft codes 52-54-82

**REAR COVERS**

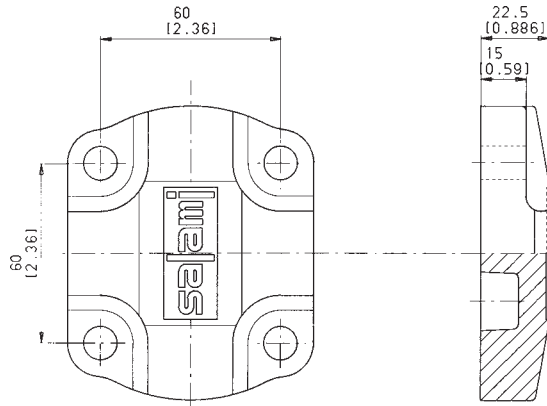

Standard rear cover  
for unidirectional pumps

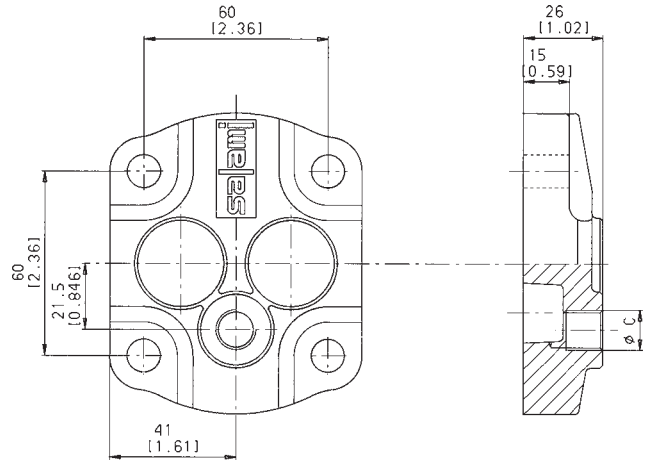

Standard cover for reversible pumps and motors,  
with external drain  $\Phi C$ .  
For the dimension  $\Phi C$  please see the table here below.

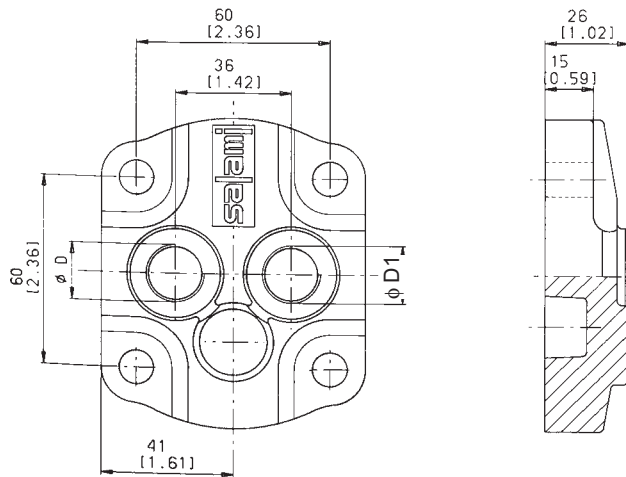

For pumps with threaded rear ports.  
On request outlet port only.

**PUMPS**

D	D1
M 18x1.5	M 26x1.5
7/8-14 UNF-2B (SAE 10)	1-1/16-12 UN-2B (SAE 12)
G 1/2	G 3/4

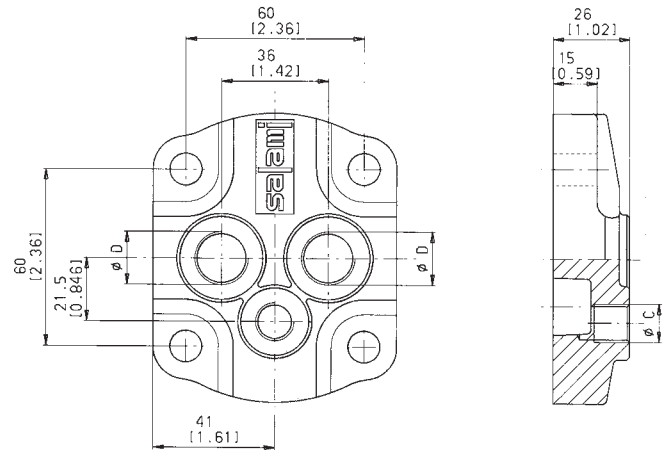

For motors with threaded rear ports  
until 22 l/min delivery.

**MOTORS**

D	C
M 18x1.5	G 1/4
7/8-14 UNF-2B (SAE 10)	7/16-20 UNF-2B (SAE 4)
G 1/2	G 1/4

**code 1**

For rear ports if requested please  
advise type using note.



## REAR COVER FOR MULTIPLE PUMP 2PB / 1PB

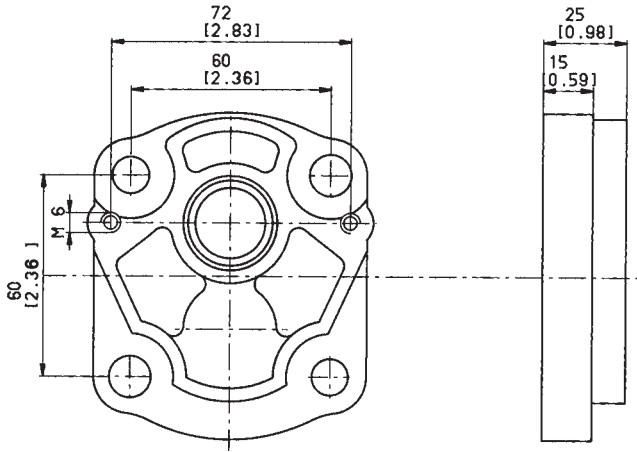

**code PD1**

Cover for 2PB/1PB

Order example: **2PB 8.3D - P28 P1 - PD1.....**

## REAR COVERS WITH MAIN RELIEF VALVES

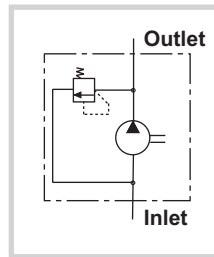
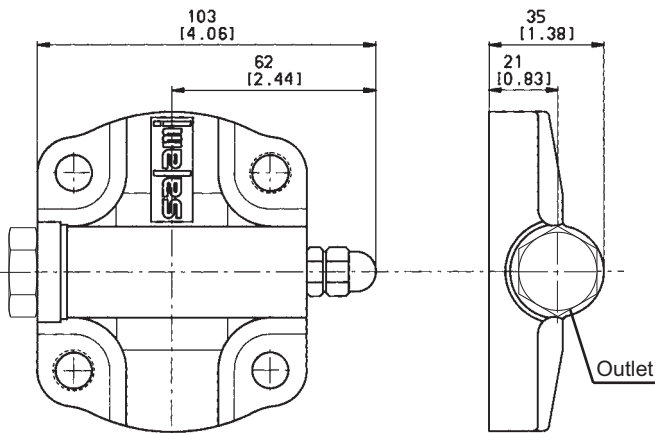

**code VS**

With main relief valve with internal exhaust gallery

For this main relief valve you can choice four setting ranges:

- ( 20 - 50 bar )
- ( 51 - 75 bar )
- ( 76 - 150 bar )
- ( 151 - 220 bar )

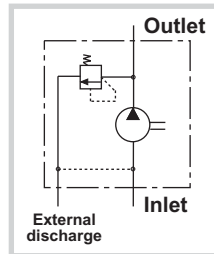
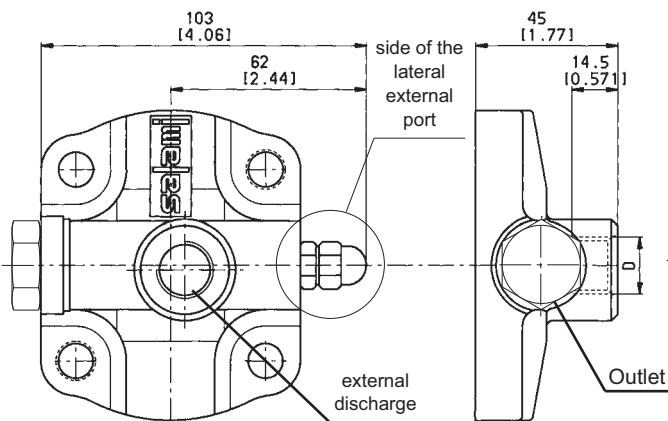

**code VSE**

**code VSL**

With main relief valve with external exhaust gallery

<b>D (external discharge)</b>
M 18 x 1.5 (METRIC)
3/4-16 UNF-2B (SAE 8)
G 3/8 (BSP)

Lateral external exhaust port

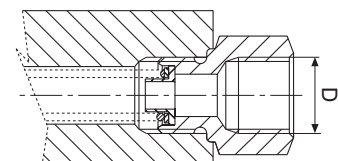

**REAR COVER WITH PRESSURE COMPENSATED FLOW CONTROL VALVE**

**code VR** Pressure compensated flow control valve with excess flow to tank

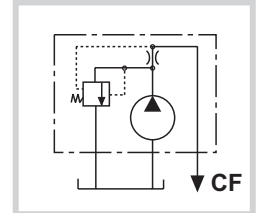

**code VRS** Pressure compensated flow control valve with excess flow to tank, with main relief valve on controlled flow line.

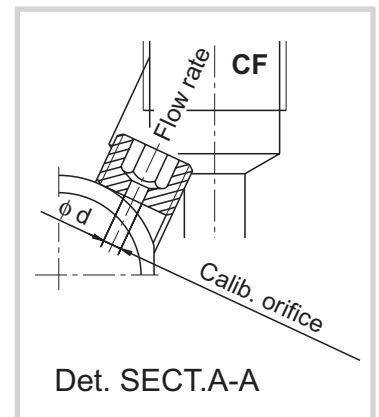
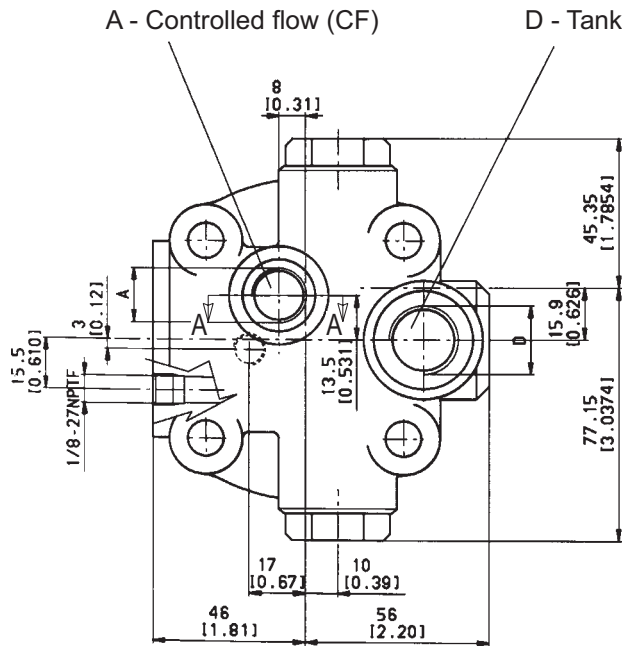
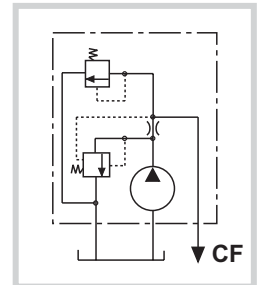

A	D
G 3/8	G 1/2
9/16-18 UNF-2B (SAE 6)	3/4-16 UNF-2B (SAE 8)

**FLOW CONTROL VALVE (VR - VRS)**

3 - way flow control valve housed in a special cast iron cover which ensures constant flow regardless pump speed and system pressure variations. It can also be supplied with adjustable pressure relief valve whose relieved flow goes into excess pump flow line. In this way the max fluid temperature is lower than obtained if the excess flow returned directly to pump inlet. The flow regulated is determined by the diameter of hole on the threaded dowel (see table).

CALIBRATED ORIFICE Ø d(mm/inch)	FLOW RATE (l/min - gpm) ± 10%
1.5 (0.06")	2.5 (0.66)
2 (0.08")	4 (1.06)
2.4 (0.09")	6 (1.59)
2.8 (0.11")	8 (2.11)
3.1 (0.12")	10 (2.64)
3.5 (0.14")	12.5 (3.30)
4 (0.16")	16 (4.23)
4.4 (0.17")	20 (5.28)
4.9 (0.19")	25 (6.61)



## REAR COVER WITH PRESSURE COMPENSATED PRIORITY FLOW VALVE

**code VP** Priority flow valve, excess flow to second actuator.

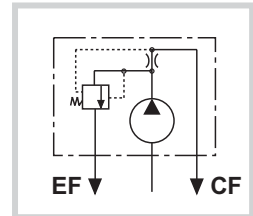

**code VPS** Priority flow valve, excess flow to second actuator with pressure relief valve on priority flow line.

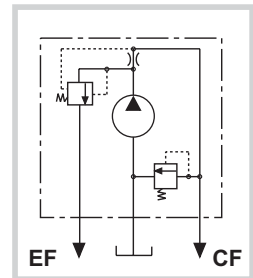

A - Priority flow (CF)      D - Excess flow (EF)

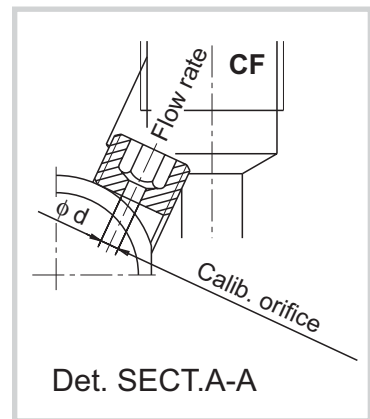
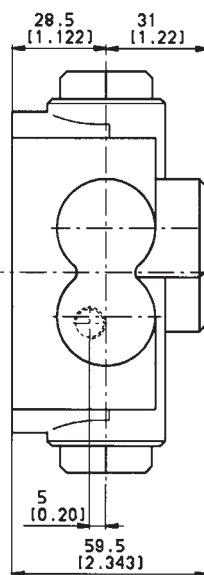
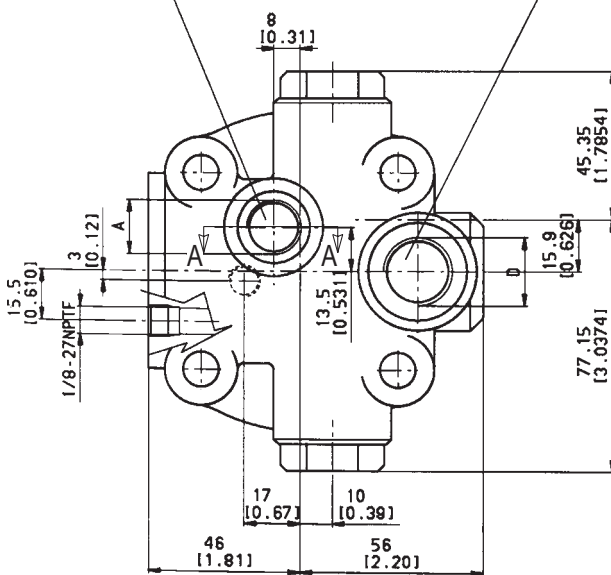

A	D
G 3/8	G 1/2
9/16-18 UNF-2B (SAE 6)	3/4-16 UNF-2B (SAE 8)

### PRIORITY FLOW DIVIDERS ( VP - VPS )

These are basically the same as VR valves differing only because the two flows can be loaded at the same time for supplying two separate circuits defined priority flow remains constant regardless of pump speed and system pressure variations. The second defined excess flow is directly proportional to pump speed. Priority flow is determined by diameter of hole on threaded dowel (see table). The max. pressure of the priority circuit can be limited by valve which relieves into pump suction.

CALIBRATED ORIFICE Ø d(mm/inch)	FLOW RATE (l/min - gpm) ± 10%
1.5 (0.06")	2.5 (0.66)
2 (0.08")	4 (1.06)
2.4 (0.09")	6 (1.59)
2.8 (0.11")	8 (2.11)
3.1 (0.12")	10 (2.64)
3.5 (0.14")	12.5 (3.30)
4 (0.16")	16 (4.23)
4.4 (0.17")	20 (5.28)
4.9 (0.19")	25 (6.61)

**REAR COVER WITH LOAD-SENSING PRIORITY VALVES**

**code VPL**

Load sensing priority valve with main relief valve



**code VPD**

Load sensing priority valve with dynamic signal and main relief valve

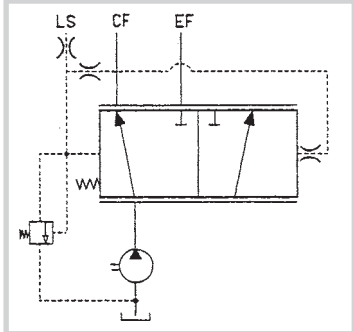
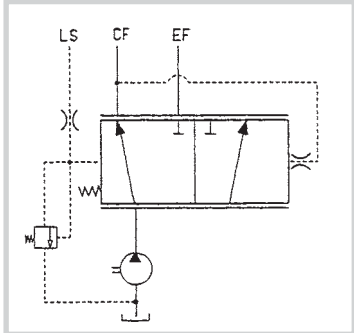

A - Priority flow port (CF)      D - Excess flow port (EF)

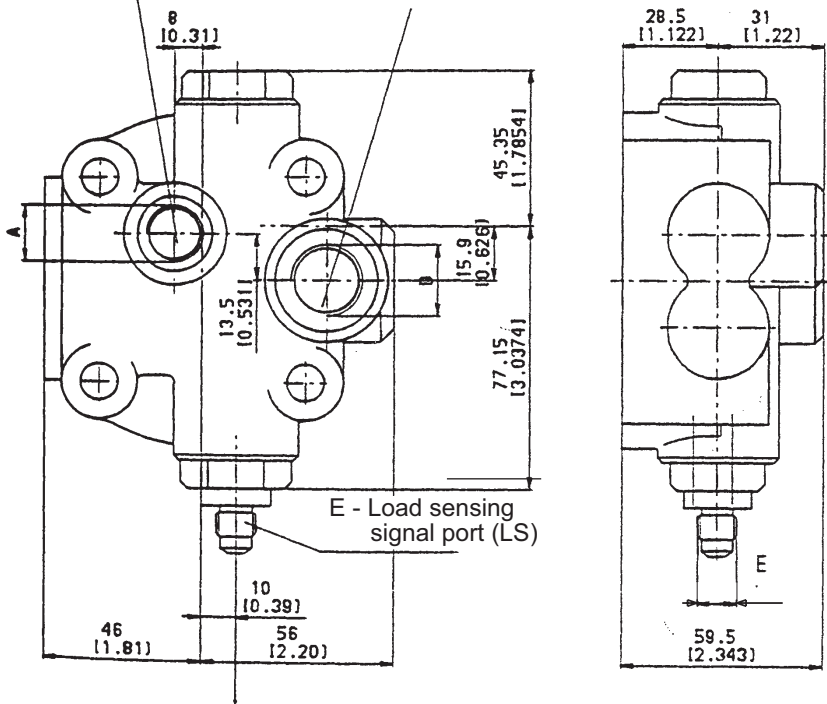

LS = Load sensing signal port  
CF = Priority flow port  
EF = Excess flow port

PRIORITY FLOW RATE	
l / min ± 10%	gpm ± 10%
8	2.10
10.5	2.61
12.5	3.78
16	4.17
20	5.22

Minimum load sensing signal (LS) = 4 bar (28 psi)

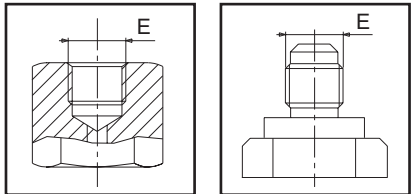

A	D	E
G 3/8	G 1/2	G 1/4
9/16-18 UNF-2B (SAE 6)	3/4-16 UNF-2B (SAE 8)	7/16 UNF

Side ports also availables. Please specify with note.

## REAR COVER WITH ELECTRIC UNLOADING VALVE

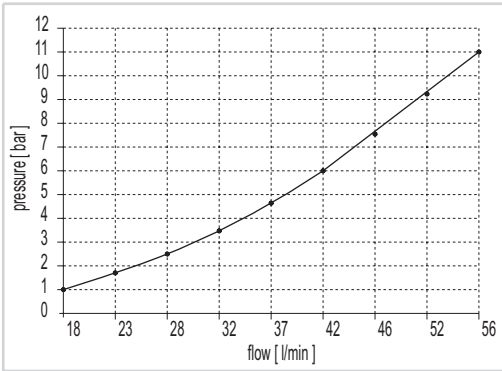

**code EV**

**EV1 - 12 Vcc**  
**EV2 - 24 Vcc**

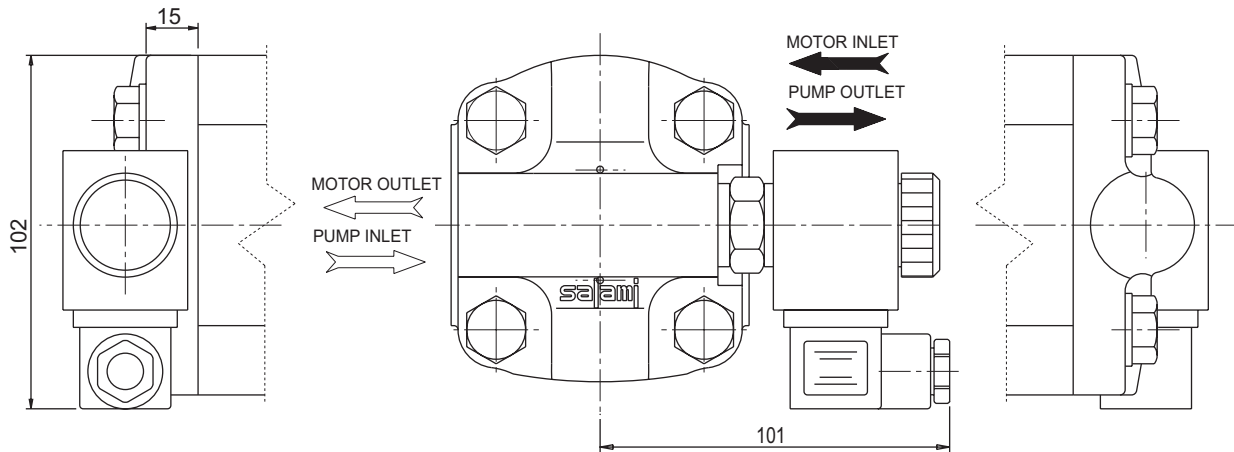
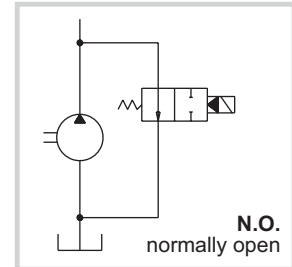

**code EVS**

Cover with built-in relief and electric unloading valve

**EVS1 - 12 Vcc**  
**EVS2 - 24 Vcc**

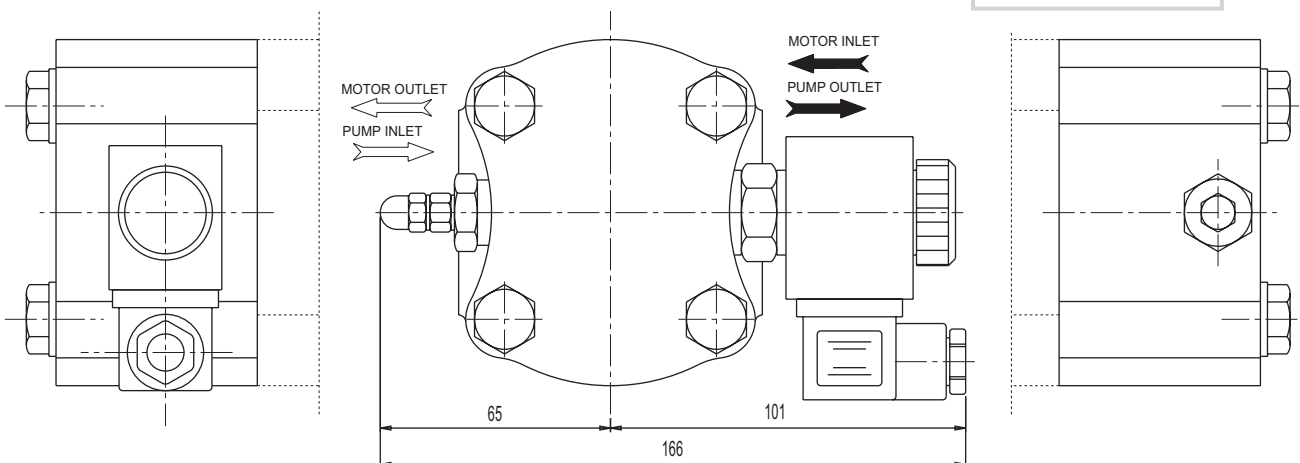
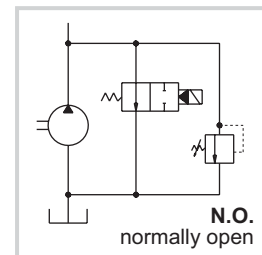

**ASSEMBLING DIMENSIONS**



Type	3.2	3.9	4.5	6.2	8.3	11.3	13.8	16	19	22.5	26
Dimension A (flanges B2 - B3)						16,5 0.65					
Dimension A (flanges P1 - S2 - B1)						19 0.75					
Dimension B			23,5 0.92				31,7 1.25	37 1.46	40,2 1.58	42,9 1.69	45.8 1.78
Dimension H			47,1 1.85		52,8 2.10		63.5 2.50	74 2.91	80.4 3.16	85.8 3.38	91.6 3.61

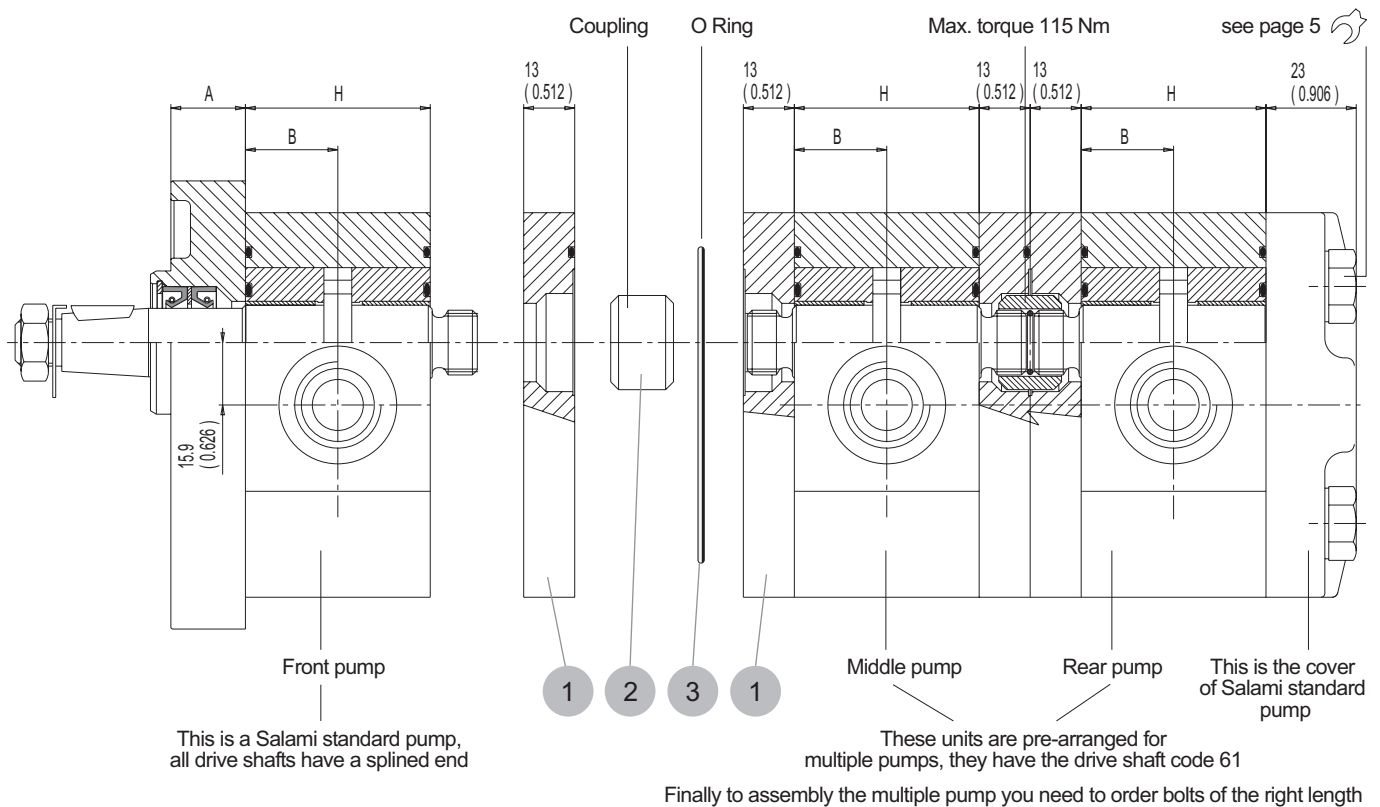

1 2 3 = kit multiple pumps

The **2PB** pumps can be easily transformed into front pump in the multiple units. All drive shafts are pre-arranged and have a splined end according DIN 5482. The first unit must always be the same size or bigger than following units. The features and performances are the same of the corresponding single units: only in the case of simultaneous operating you have to verify that the inlet torque is lower than the max. transmissible by the drive shaft.

## MULTIPLE PUMP WITH SEPARATED STAGES

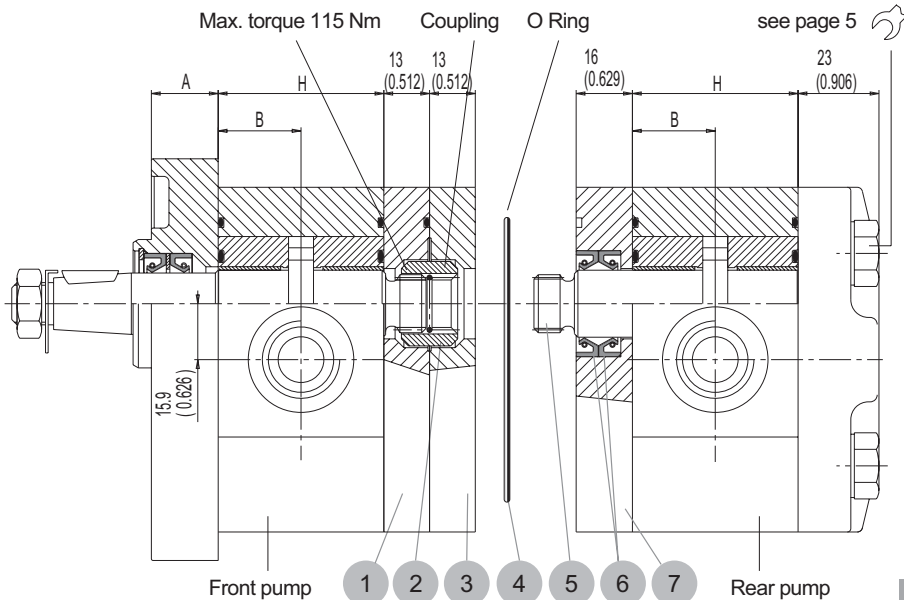

Multiple pump with separated stages components kit:

- 1 2 3 4 5 6 7

the drive shaft 5 is longer than standard code 61

Finally to assembly this pump you need to order bolts of the right length

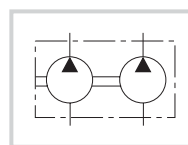

**code AS**

Order example:

**2PB 11.3/2PB 8.3D - P28 P1 - AS**

For dimension ( A - B - H ) see page 23

## 2PB COMBINATION WITH 1PB

For dimension rear pump see catalogue: GEAR PUMPS AND MOTORS - GROUP 1

Rear cover code PD1 (see page 18)

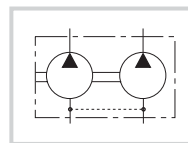
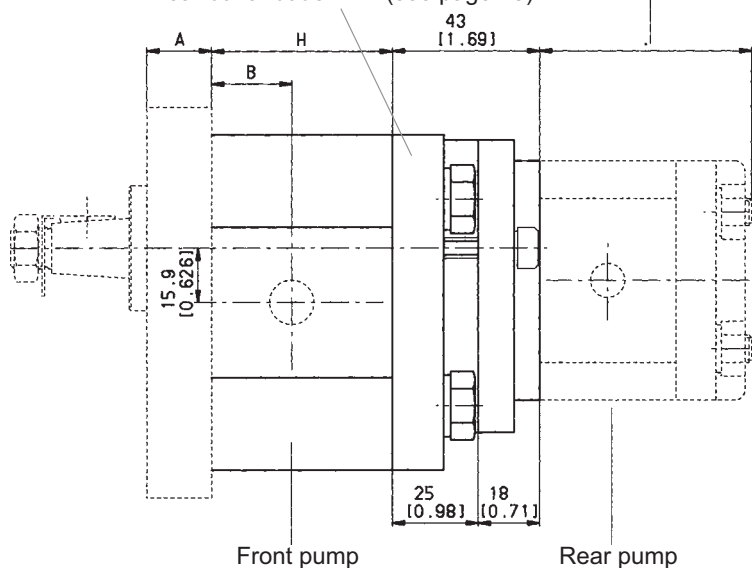

Order examples:

**2PB 8.3/1PB 3D - P28 P1**

For dimension ( A - B - H ) see page 23

A=250 bar - (3600 psi)  
 B=200 bar - (2900 psi)  
 C=150 bar - (2175 psi)  
 D=100 bar - (1450 psi)  
 E=50 bar - (725 psi)

# 2PB / Group 2

Performance curves carried out with oil viscosity at 16 cSt and oil temperature at 60°C

## PUMP PERFORMANCE CURVES

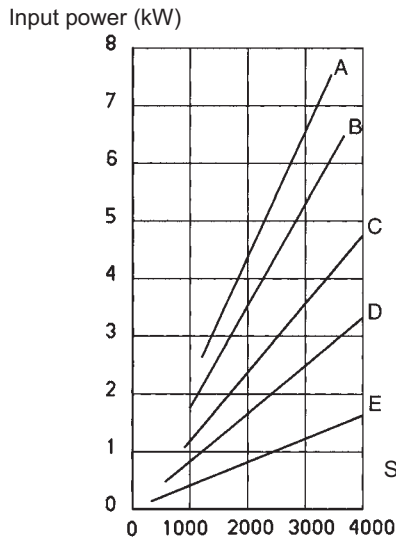

2PB 4.5

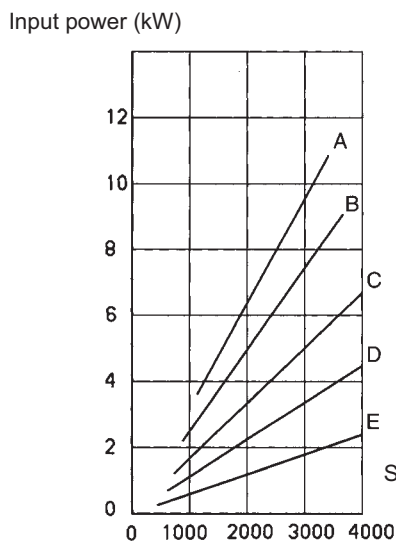
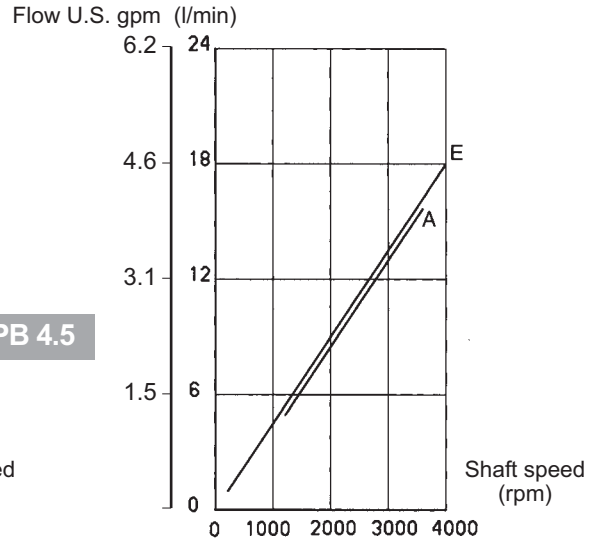

2PB 6.2

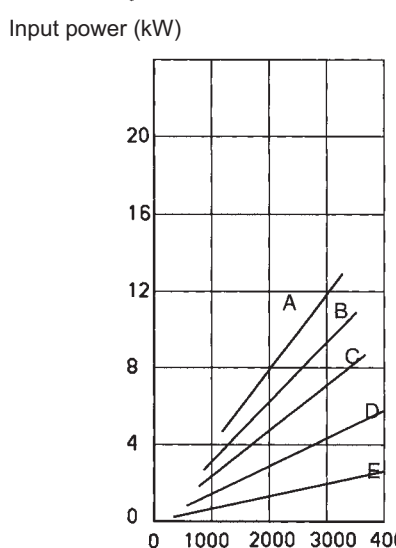
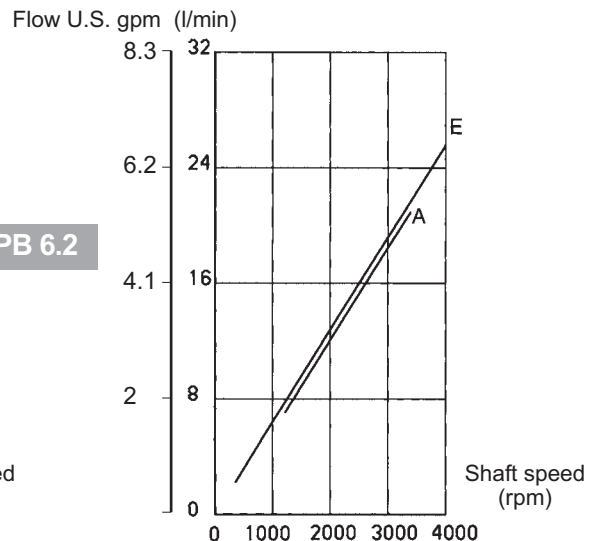

2PB 8.3

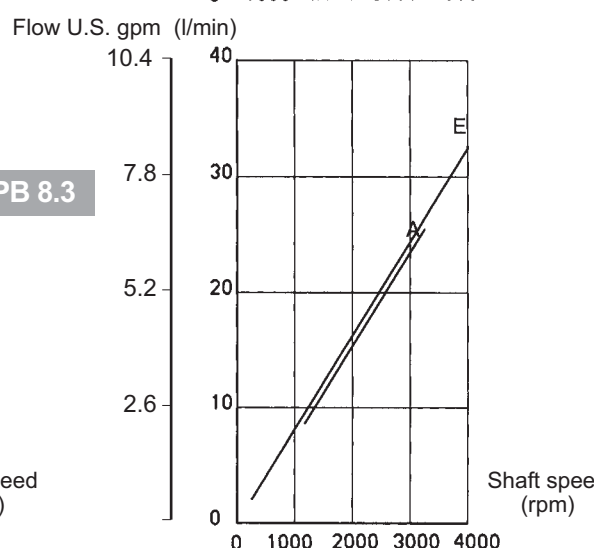



# 2PB / Group 2

A=250 bar - (3600 psi)  
 B=225 bar - (3250 psi)  
 C=200 bar - (2900 psi)  
 D=150 bar - (2175 psi)  
 E=100 bar - (1450 psi)  
 F= 50 bar - ( 725 psi)

Performance curves carried out with oil viscosity at 16 cSt and oil temperature at 60°C

Input power (kW)

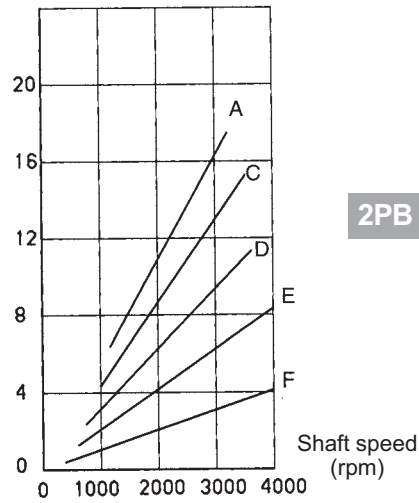

Flow U.S. gpm (l/min)

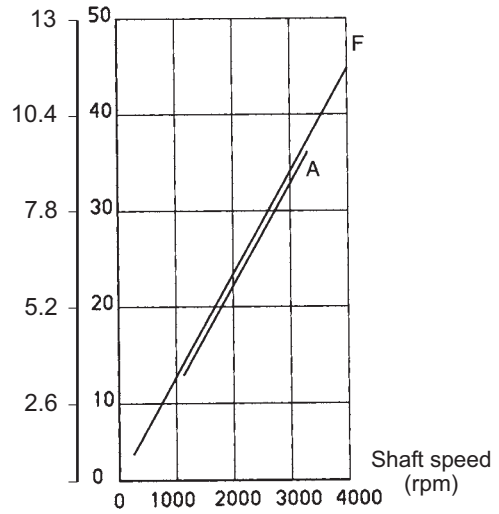

2PB 11.3

Input power (kW)

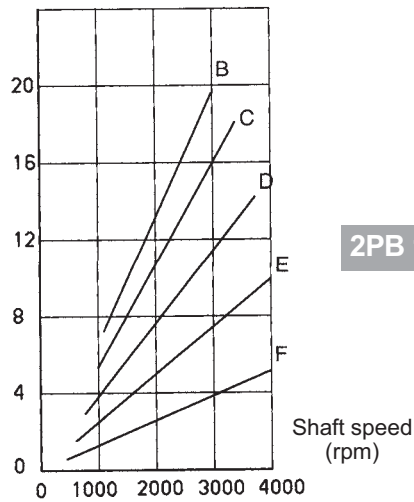

Flow U.S. gpm (l/min)

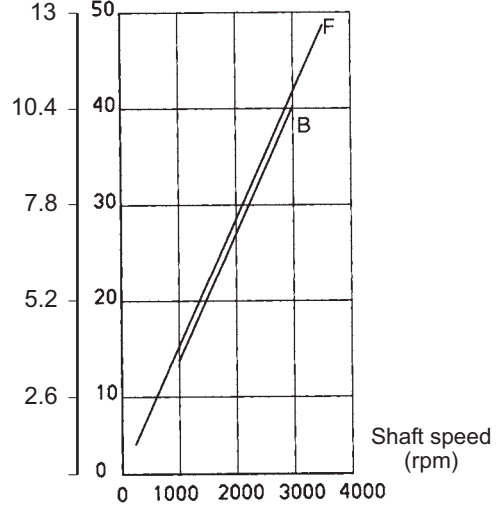

2PB 13.8

Input power (kW)

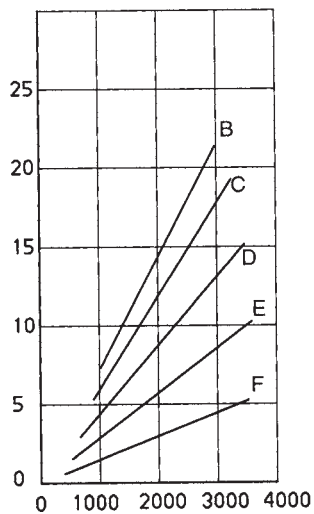

Flow U.S. gpm (l/min)

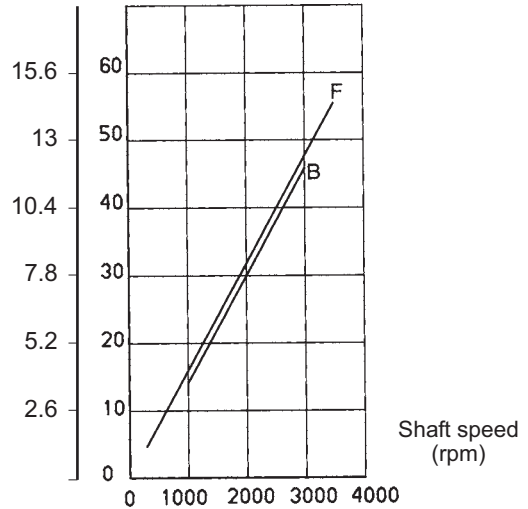

2PB 16

A=250 bar - (3600 psi)  
 B=200 bar - (2900 psi)  
 C=150 bar - (2175 psi)  
 D=100 bar - (1450 psi)  
 E=50 bar - (725 psi)

# 2PB / Group 2

Performance curves carried out with oil viscosity at 16 cSt and oil temperature at 60°C

Input power (kW)

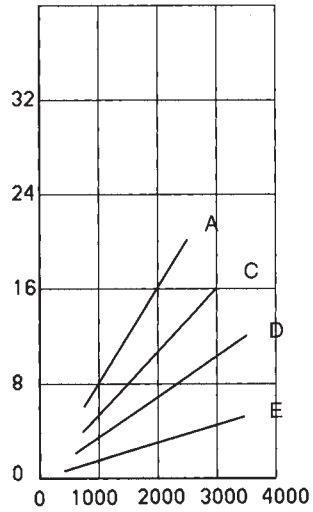

2PB 19

Flow U.S. gpm (l/min)

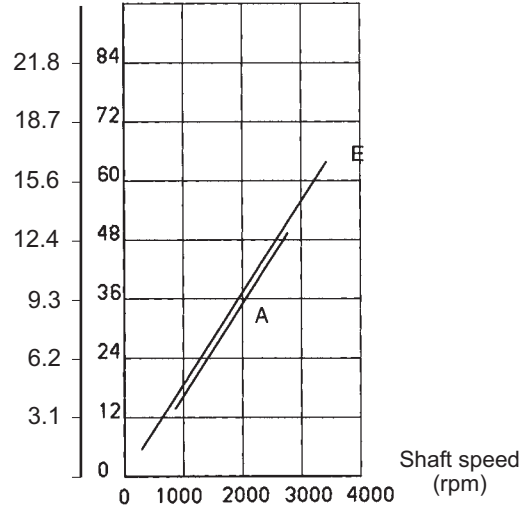

Input power (kW)

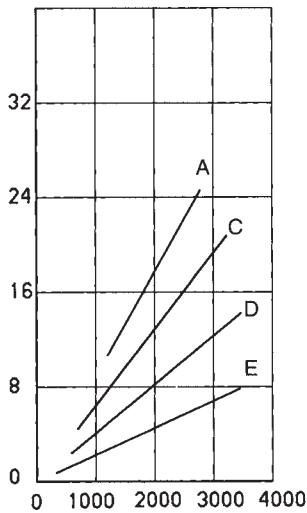

2PB 22.5

Flow U.S. gpm (l/min)

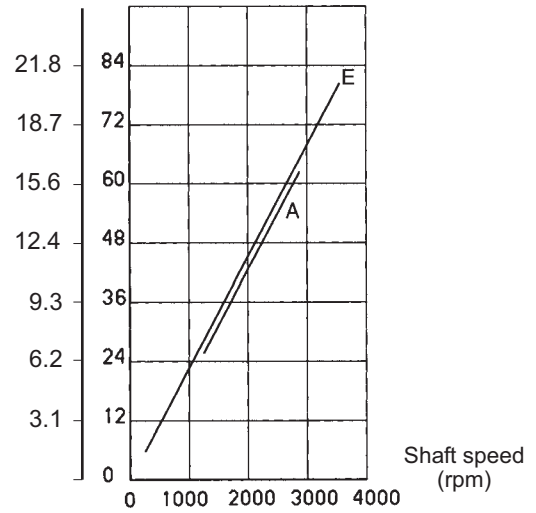

Input power (kW)

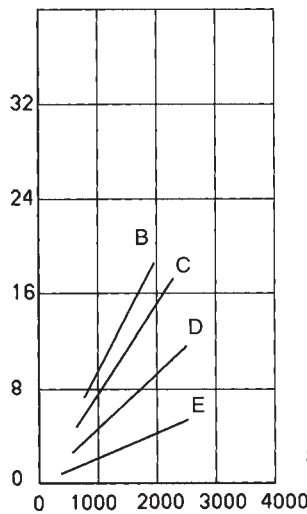

2PB 26

Flow U.S. gpm (l/min)

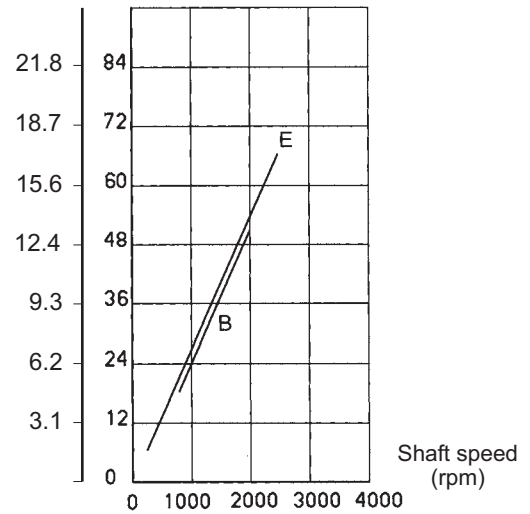

# 2MB / Group 2

\_\_\_\_\_ Torque  
 - - - - - Output  
 A=210 bar (3000 psi) D=105 bar (1500 psi)  
 B=175 bar (2530 psi) E= 70 bar (1000 psi)  
 C=140 bar (2000 psi) F= 35 bar (500 psi)

Performance curves carried out with oil viscosity at 16 cSt and oil temperature at 60°C

## MOTOR PERFORMANCE CURVES

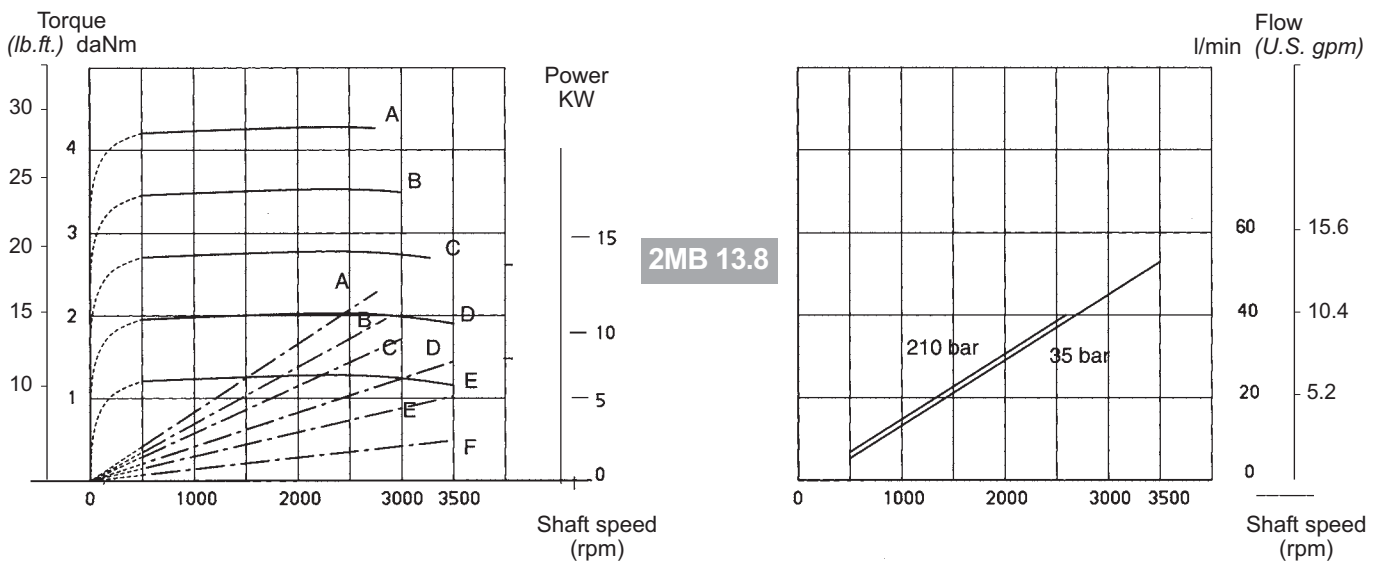
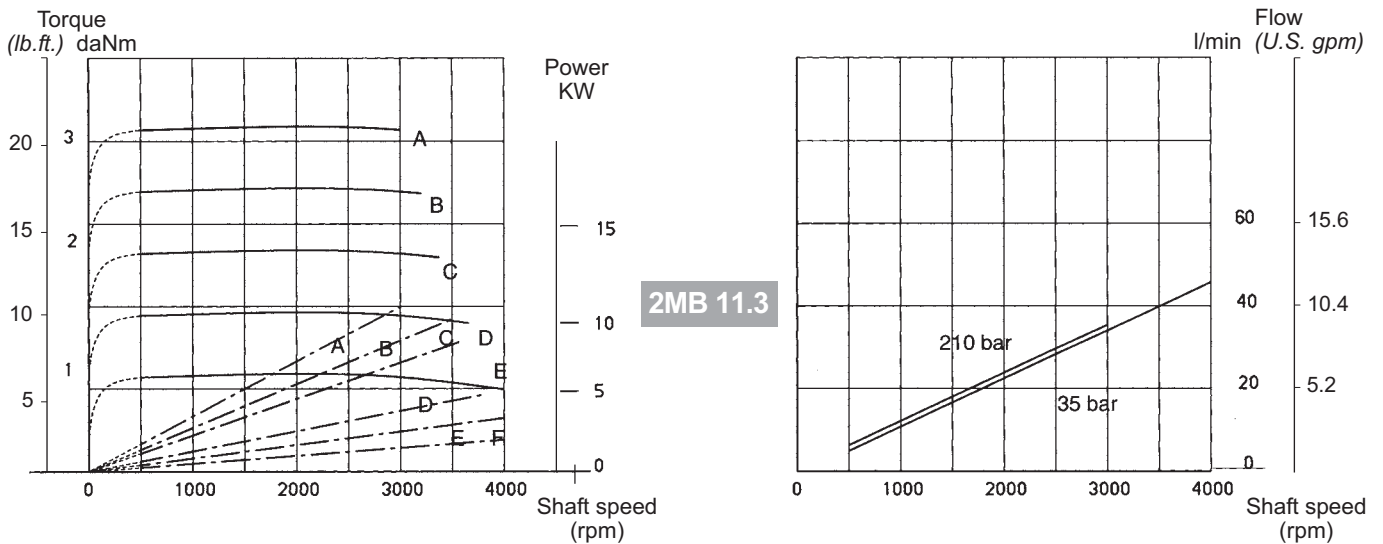
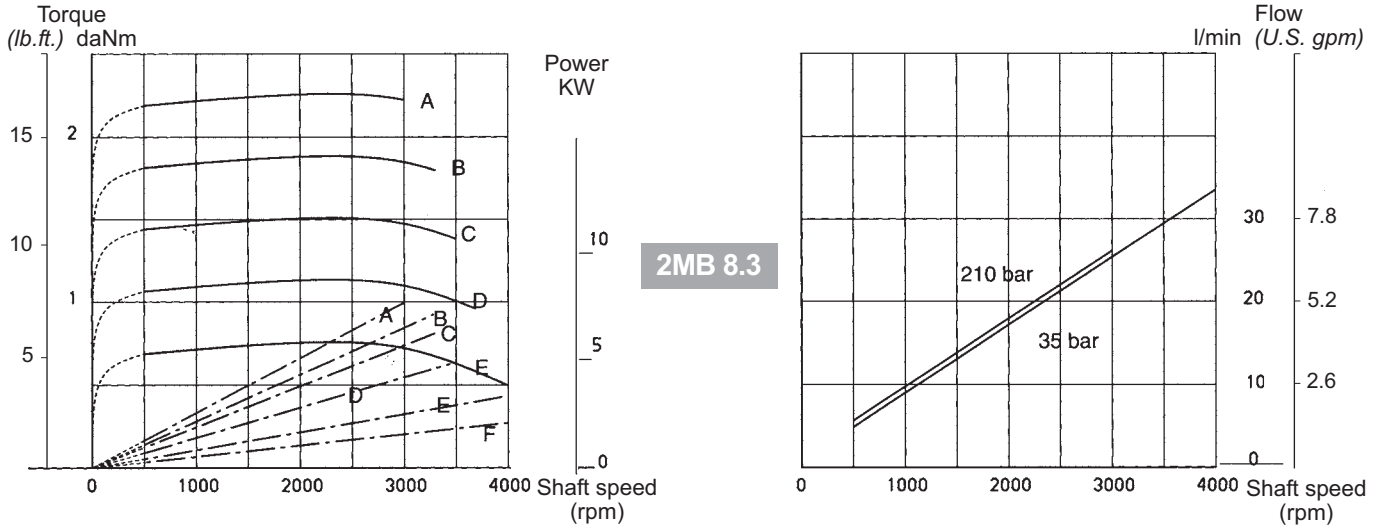

Torque \_\_\_\_\_  
 Output - - - - -

A=210 bar (3000 psi) D=105 bar (1500 psi)  
 B=175 bar (2530 psi) E= 70 bar (1000 psi)  
 C=140 bar (2000 psi) F= 35 bar (500 psi)

# 2MB / Group 2

Performance curves carried out with oil viscosity at 16 cSt and oil temperature at 60°C

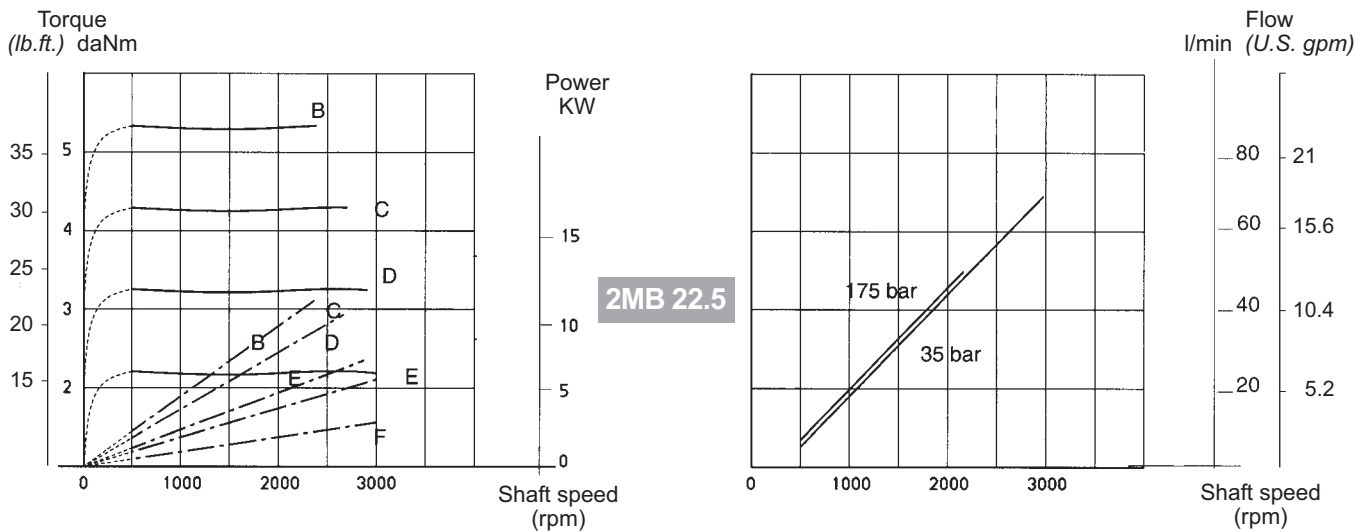
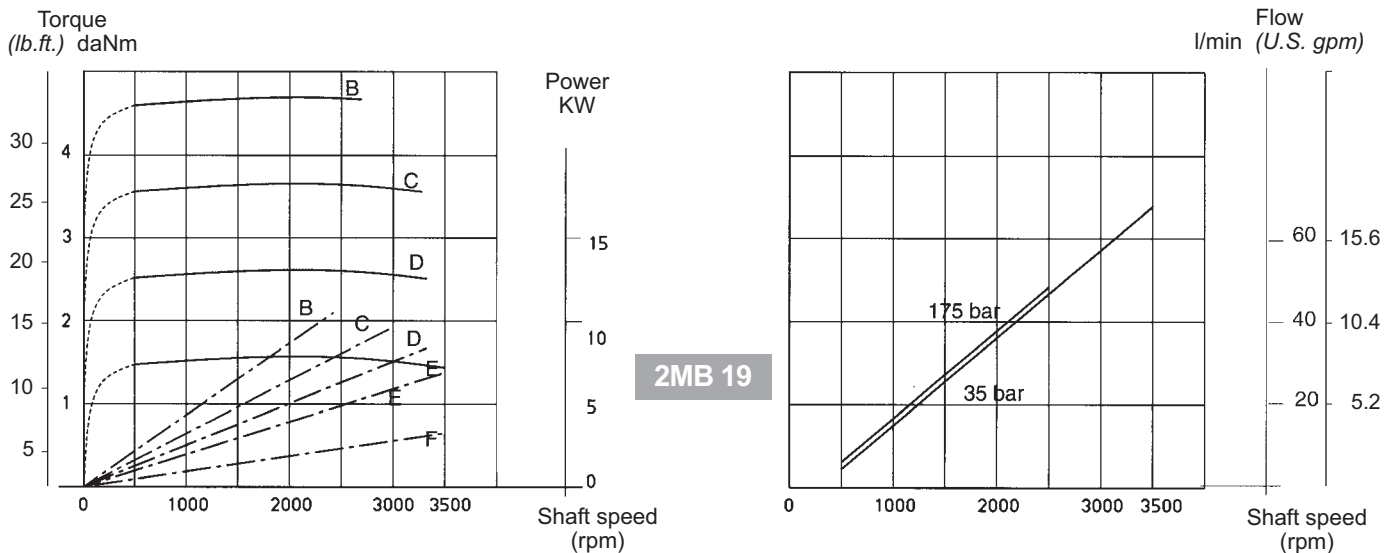
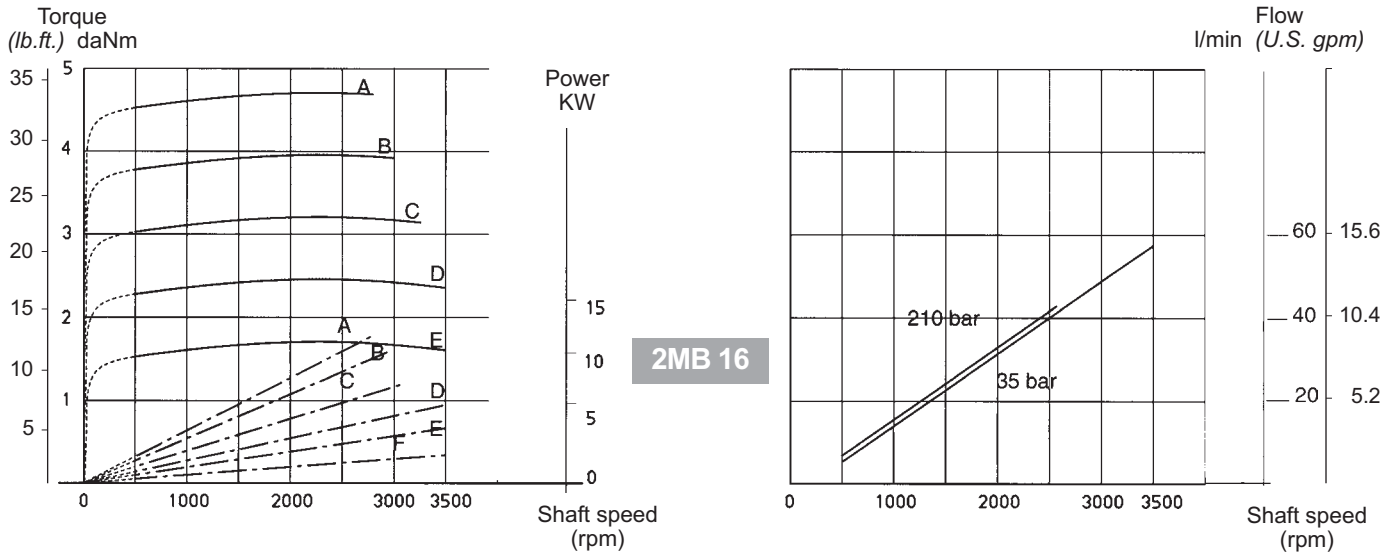

# 2P/MB / Group 2

————— Torque  
 - - - - - Output

A=210 bar (3000 psi) D=105 bar (1500 psi)  
 B=175 bar (2530 psi) E= 70 bar (1000 psi)  
 C=140 bar (2000 psi) F= 35 bar (500 psi)

Performance curves carried out with oil viscosity at 16 cSt and oil temperature at 60°C

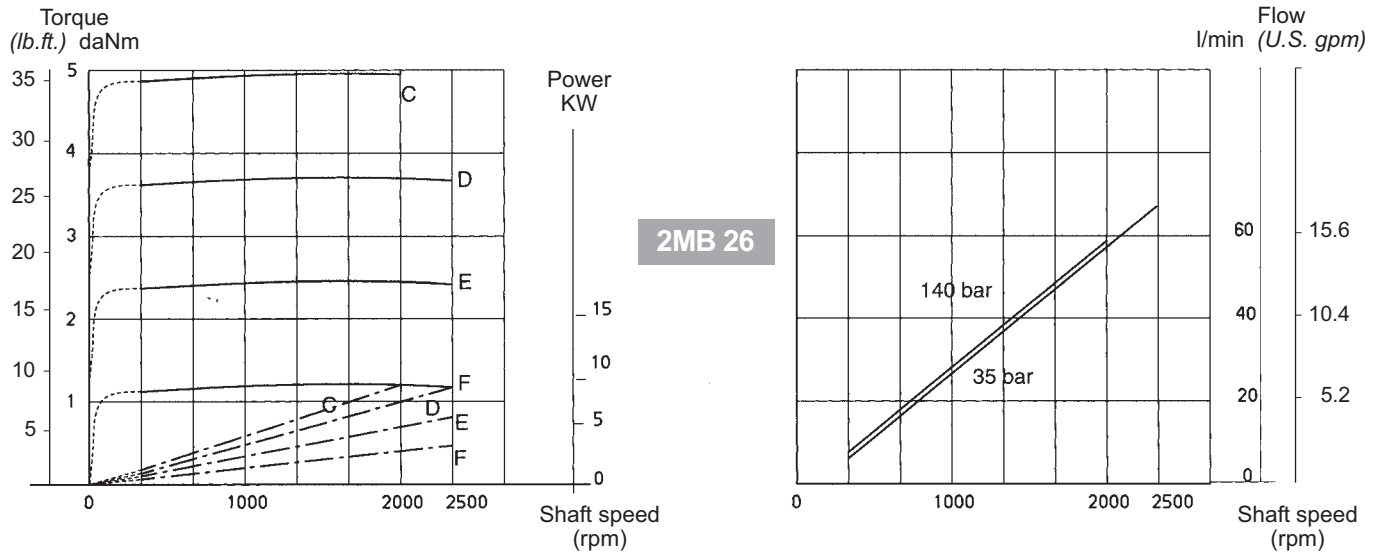

## PORT CONNECTORS

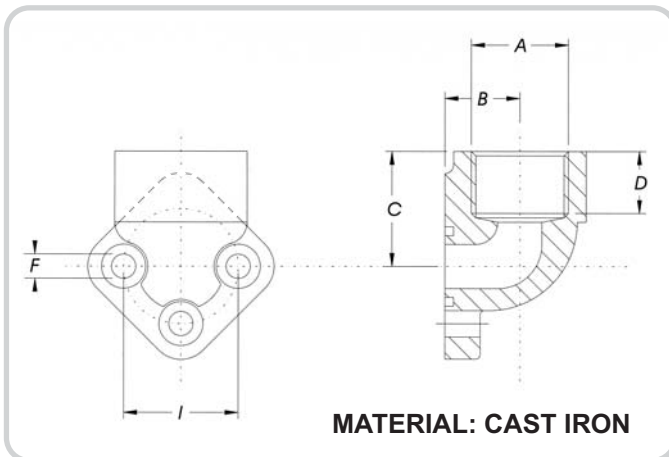

**Type G**

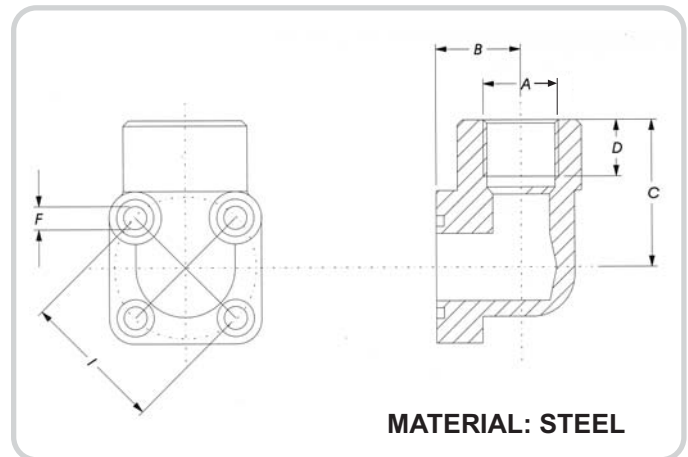

**Type GB**

### AVAILABLE CONNECTORS - DIMENSIONS AND CODE

Type	C	B	I	D	Ø F	Ø A	ORDERING CODE COMPLETE OF SCREW - SPRING WASHER - O RING
1 G/1	26	17.5	30	14	6.5	M18x1.5	4352 7004 0
1 G/2	26	17.5	30	14	6.5	G 3/8	4352 7005 0
1 G/3	26	17.5	30	14	6.5	G 1/2	4352 7006 0
2 G	36	21	40	16	8.5	G 3/4	4352 7011 0
1 GB/1	40	18	35	16	6.5	M18x1.5	4352 7008 1
1 GB/2	40	18	35	16	6.5	G 3/8	4352 7009 1
1 GB/3	40	18	35	16	6.5	G 1/2	4352 7010 1
2 GB	41.5	24	40	16	6.5	G 3/4	4352 7012 1

**SINGLE PUMPS/MOTORS**

2 P B 16 D - P 28 P1 - V 1 - CP - PD1 - VS

**DIMENSION**

FUNCTION	CODE
Pump	P
Motor	M

**SERIES**

TYPE	DISPLACEMENTS	
4.5	4.6 cm <sup>3</sup> /rev.	0,27 cu.in/rev.
6.2	6.5 cm <sup>3</sup> /rev.	0,40 cu.in/rev.
8.3	8.2 cm <sup>3</sup> /rev.	0,50 cu.in/rev.
11.3	11.5 cm <sup>3</sup> /rev.	0,68 cu.in/rev.
13.8	13.8 cm <sup>3</sup> /rev.	0,84 cu.in/rev.
16	16.6 cm <sup>3</sup> /rev.	1.01 cu.in/rev.
19	19.4 cm <sup>3</sup> /rev.	1.15 cu.in/rev.
22.5	22.9 cm <sup>3</sup> /rev.	1.37 cu.in/rev.
26	25.8 cm <sup>3</sup> /rev.	1.58 cu.in/rev.

ROTATION	CODES
Clockwise	D
Anti-clockwise	S
Reversible	R

PORTS (pag. 11)	CODES
Flanged ports european standard	P
Flanged ports german standard	B
GAS threaded ports (BSPP)	G
SAE Threaded ports (ODT)	R

DRIVE SHAFTS (pag. 12 - 13)	CODES
Tang drive for engine driven	02
Tang drive for electric motors	03
Tapered 1:5	25
Tapered 1:5 (only for CB)	26
Tapered 1:8	28
SAE A splined 9 T	52
SAE A splined 11 T	54
DIN 5482 splined	61
DIN 5482 splined shaft	62
Parallel shaft Ø 15	81
SAE A parallel shaft Ø 15,87	82
SAE A parallel shaft Ø 19,05	85

\*The assembling is the same of that of page 18.

Setting main relief valve (bar)

Adjusted flow l/min

PD1=pre-arranged for 1PB rear (pag.18)

VALVES IN THE COVER	CODES
Adjustable main relief valve (pag.18)	VS
Fixed setting main relief valve*	VSF
Like VS with external discharge (pag.18)	VSE
Like VS with lateral external discharge(pag.18)	VSL
Like VSF with external discharge*	VSEF
Flow regulator with excess flow to tank(pag.19)	VR
Priority flow divider with excess flow to 2 nd actuator(pag.20)	VP
Like VR with main relief valve(pag.19)	VRS
Like VP with main relief valve(pag.20)	VPS
Priority flow divider with Load-sensing(pag.21)	VPL
Like VPL with dinamic signal(pag.21)	VPD
Electric unloading valve (12 V) (pag.22)	EV1
Electric unloading valve (24 V) (pag.22)	EV2
Main relief and electric unloading valves (12V) (pag.22)	EVS1
Main relief and electric unloading valves (24 V) (pag.22)	EVS2

OUTRIGGER BEARINGS (pag. 15 - 16)	CODES
European standard	CP
German standard	CB
For engine endothermic motors	CL
For endothermic motors with axial and radial loads	CF
SAE A	CS

PORTS POSITION	CODE
Lateral ports standard	
Rear ports (pag. 17)	1

SEAL	CODE
Buna Standard	
Viton	V

MOUNTING FLANGES (pag. 13 - 14)	CODES
European standard	P1
German standard Ø 80	B1
German standard Ø 52	B2-B3
German standard Ø 50	B4-B5
SAE A 2 bolts	S2
SAE A 2 bolts (with O-ring on the centering collar)	S6
4 bolts for Perkins Motor	K1

Order example:

Pump 2PB 19D, ports SAE (R), drive shaft (52), mounting flange (S2) with valve in the cover (VPS 12,5 l/min) and pressure relief valve setting 180 bar: 2PB 19D-R52 S2-VPS12,5/180



## MULTIPLE PUMPS

2PB 16 / 16 13.8 D - P 28 P1 - V AS 1 - CP - PD1 1PB...

TYPE	DISPLACEMENTS	
3.2	3.2 cm <sup>3</sup> /rev.	0.19 cu.in/rev.
3.9	3.9 cm <sup>3</sup> /rev.	0.24 cu.in/rev.
4.5	4.6 cm <sup>3</sup> /rev.	0,27 cu.in/rev.
6.2	6.5 cm <sup>3</sup> /rev.	0,40 cu.in/rev.
8.3	8.2 cm <sup>3</sup> /rev.	0,50 cu.in/rev.
11.3	11.5 cm <sup>3</sup> /rev.	0,68 cu.in/rev.
13.8	13.8 cm <sup>3</sup> /rev.	0,84 cu.in/rev.
16	16.6 cm <sup>3</sup> /rev.	1.01 cu.in/rev.
19	19.4 cm <sup>3</sup> /rev.	1.15 cu.in/rev.
22.5	22.9 cm <sup>3</sup> /rev.	1.37 cu.in/rev.
26	25.8 cm <sup>3</sup> /rev.	1.58 cu.in/rev.

ROTATION	CODES
Clockwise	D
Anti-clockwise	S

PORTS (pag. 11)	CODES
Flanged ports european standard	P
Flanged ports german standard	B
GAS threaded ports (BSPP)	G
SAE Threaded ports (ODT)	R

DRIVE SHAFTS (pag. 12 - 13)	CODES
Tang drive for engine driven	02
Tang drive for electric motors	03
Tapered 1:5	25
Tapered 1:5 (only for CB)	26
Tapered 1:8	28
SAE A splined 9 T	52
SAE A splined 11 T	54
DIN 5482 splined shaft	62
Parallel shaft Ø 15	81
SAE A parallel shaft Ø 15,87	82
SAE A parallel shaft Ø 19,05	85

OUTRIGGER BEARINGS (pag. 15 - 16)	CODES
European standard	CP
German standard	CB
For engine endothermic motors	CL
For endothermic motors with axial and radial loads	CF
SAE A	CS

PORTS POSITION	CODES
Lateral ports standard	
Rear ports (pag.17)	1

SUCTION TYPES	CODES
Common suction (pag.23)	UA*
Separated tank (pag.24)	AS

SEAL	CODE
Buna Standard	
Viton	V

MOUNTING FLANGES (pag. 13 - 14)	CODES
European standard	P1
German standard Ø 80	B1
German standard Ø 52	B2-B3
German standard Ø 50	B4-B5
SAE A 2 bolts	S2
SAE A 2 bolts (with O-ring on the centering collar)	S6
4 bolts for Perkins Motor	K1

See corresponding single pump ( 1PB )

PD1 = pre-arranged for 1PB rear(pag.18)

Available only as rear pump

\*UA: this type of multiple pump is a Salami standard multiple pump which has only one inlet port opened, all the other inlet port are closed.

In case of common suction, the code 1 - 2 or 3, correspond to the body where inlet is located.

**Example to order a tandem pump with common suction: 2PB 16/6.2D - B25 B2 - UA1**

**Example to order a triple pump with main relief in the rear pump: 2PB 13.8/8.3/4.5D - P28 P0 - VS175**

## WARRANTY

- We warrant products sold by us to be free from defects in material and workmanship.
- Our sole obligation to buyer under this warranty is the repair or replacement, at our option, of any products or parts thereof which, under normal use and proper maintenance, have proven defective in material or workmanship, this warranty does not cover ordinary wear and tear, abuse, misuse, averloading, alteration.
- No claims under this warranty will be valid unless buyer notifies SALAMI in writing within a reasonable time of the buyer's discovery of such defects, but in no event later than twelve (12) months from date of shipment to buyer.
- Our obligation under this warranty shall not include any transportation charges or cost of installation, replacement, field repair, or other charges related to returning products to us; or any liability for direct, indirect or consequential damage or delay. If requested by us, products or parts for which a warranty claim is made are to be returned transportation prepaid to our factory. The risk of loss of any products or parts thereof returned to SALAMI will be on buyer.
- No employee or representative is authorized to change any warranty in any way or grant any other warranty unless such change is made in writing and signed by an officer of SALAMI.



**LEHENGOAK, S. A.**